



CAROUSEL

KODAK
CAROUSEL Projector

5200



Congratulations on the purchase of your new KODAK CAROUSEL 5200 Projector. It features a handy built-in viewer that lets you show your slides in a fully lighted room. We know that you'll enjoy using your projector for many years. If you ever feel that you need advice on using it, write to our staff of photographic experts at Eastman Kodak Company, Photo Information, Department 841S, Rochester, New York 14650. Also, see the comprehensive service information beginning on page 16, and the Warranty and Service Centers at the back of this manual.

Before you start to use your new projector, learn these basic safety precautions. Keep them in mind whenever you handle or operate the equipment.

IMPORTANT SAFEGUARDS

1. Read and understand all instructions.
2. Close supervision is required when any appliance is used by those who may not understand the need for the following precautions:
 - Care must be taken as burns can occur from touching hot parts. Allow the projector to cool before replacing the projection lamp or cleaning lenses.
 - Do not operate an appliance with a damaged cord or if the appliance has been dropped or damaged—until it has been examined by a qualified service technician.
 - Be careful to place the electrical cord where you, your family, and your guests will not trip on it.
 - If an extension cord is necessary, a cord with a suitable current rating should be used. Cords rated for less amperage than the appliance may overheat.
 - Never yank the cord to pull the plug from an outlet. Grasp the plug and pull it to disconnect it.
 - This instruction manual contains directions for replacing a worn-out lamp and for cleaning the projection lens, the condenser lens, the heat-absorbing glass, and the mirror. With these exceptions, do not disassemble the projector. Incorrect reassembly can cause electric shock hazard when the projector is used subsequently.

SAVE THESE INSTRUCTIONS

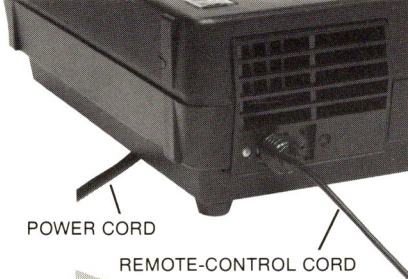

Only brief operating instructions are given on this page. Read on for important details.

1. Unwind the POWER CORD from the cord retainer on the underside of the projector. (The cord will not be wrapped around the retainer when shipped.) Remove the REMOTE-CONTROL CORD from the cord compartment at the front of the projector, next to the lens. Plug the remote-control cord into the rear of the projector. Plug the power cord into a 110- to 125-volt, 60 Hz power outlet. See page 5.

2. Place a loaded slide tray on the projector with the TRAY INDEX BAR opposite the GATE INDEX. See page 9.

3. Slide the POWER SWITCH to LO or HI. See page 9.

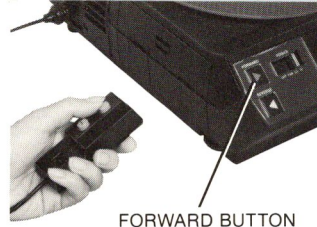

4. Briefly push the FORWARD BUTTON on the projector or the FOR (forward) button on the remote control to project the first slide on the screen. See page 9.

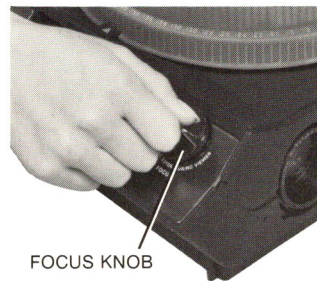

5. Rotate the FOCUS KNOB until the projected image is critically sharp. Only this first slide requires focusing if all slides are in the same type of mount. For auto-focus operation with intermixed types of slide mounts, see page 10 under "Focus."



6. Briefly push the forward button on the projector or on the remote control to change slides. *For immediate random projection of any slide in the tray, press and hold down the SELECT BAR, rotate the tray to the desired slide number, and then release the select bar.* See page 11.

To show your slides on the built-in viewer, see page 5.

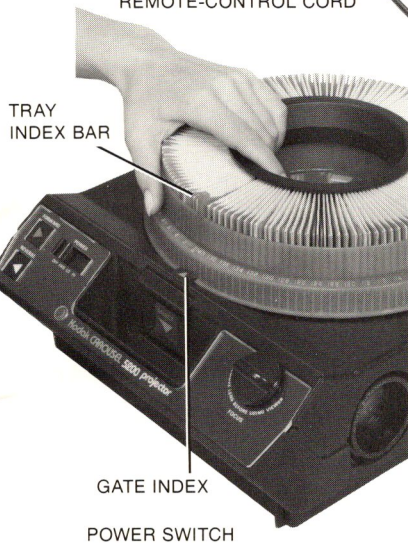

CONTENTS

Introduction	2	Projector Care	12
Serial Number	4	Projection-lamp replacement	12
Setting Up	5	Cleaning	13
Power and remote-control cords	5	Thermal fuses	14
Built-in viewer	5	Emergency slide-tray removal	15
Screen and seats	6	Projection Tips	15
Projection distances	7	Long-run applications	15
Zoom lens	7	Editing slides	15
Slide Tray	8	Service for Your Projector	16
Loading slide tray	8	Packing instructions	16
Placing slide tray on projector	9	Troubleshooting guide	17
Projecting Slides	9	Kodak Consumer Centers	18
Elevation	10	Auxiliary Equipment	20
Forward and reverse buttons	10	Warranty	OBC
Focus	10	Service Centers	OBC
Remote control	11		
Random selection of slides in trays	11		
Removing slide tray	11		
Showing single slides	11		
After the show	12		

Projection-Lamp Tips

- Rough treatment of the projector may damage the projection lamp.
- Setting the power switch at LO considerably lengthens lamp life.
- Projector operation on line voltages above 125 volts greatly reduces the lamp life.
- Unplug the power cord before changing the lamp.
- Allow for unrestricted flow of air to the exhaust vent at the rear of the projector.

SERIAL NUMBER—The serial number of your projector is stamped on the cord retainer on the underside of the projector.

Equipment subject to minor appearance changes.

SETTING UP

Power and Remote-Control Cords

Unwind the power cord from the cord retainer on the underside of the projector. (The cord will not be wrapped around the retainer when shipped.) Turn the projector upright. Open the CORD-COMPARTMENT DOOR on the front of the projector by pressing down on the latch, and remove the remote-control cord. Then close and latch the door.



CORD-COMPARTMENT DOOR

Plug the remote-control cord into the remote-control socket at the rear of the projector. The dot on the plug should be toward the bright dot to the left of the socket when the plug is in the socket.

Plug the power cord into a suitable electrical outlet. *Your CAROUSEL Projector operates on 110- to 125-volt, 60 Hz current only.* If you plug your projector into a different electrical source, the projector may be damaged.

Built-In Viewer

Use the built-in viewer to project your slides in a fully lighted room for your own viewing or for a small group of people. It provides a handy means of editing your slides.

To use the viewer:

1. **Before opening the viewer, you must remove the projection lens from the projector.** Turn the FOCUS KNOB clockwise until the lens is out as far as it will go. Carefully move the knob toward the top of the projector as you withdraw the lens. Put the lens aside in a safe spot.



FOCUS KNOB

2. Grasp the VIEWER HANDLE and move it all the way out from the base of the projector to open the viewer.

You can then move the power switch to LO or HI and project single slides, trays of slides, or stacks of slides as described on pages 9 to 11. Adjust the focus by turning the focus knob (see page 10).

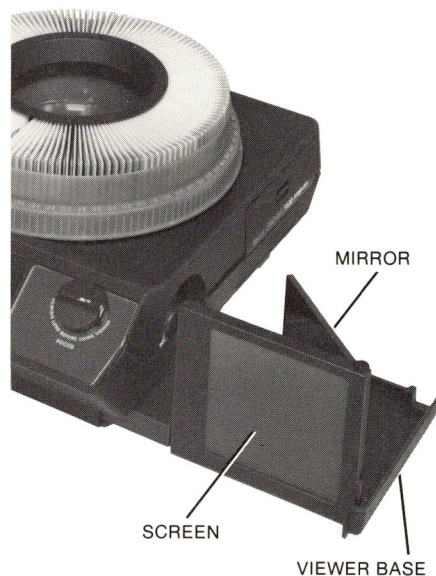

To close the viewer:

1. Press the hinged MIRROR carefully against the SCREEN.
2. Lower the screen and the mirror together into the VIEWER BASE.
3. Slide the viewer all the way back into the projector.

Screen and Seats

For projection on a *large* screen, the room should be darkened sufficiently to enable a brilliant image to be projected. This doesn't mean that the room has to be totally dark.

Because slides may be square, horizontal, or vertical in format, a square screen is usually most convenient. It should be large enough for easy viewing by everyone present. If possible, your projector should be at the same level as the center of the screen.

For easy viewing, your audience should not be farther from the screen than six times the longer dimension of the projected image. See the chart listing projector-to-screen distances on the next page. Place the seats as close as possible to both sides of the beam thrown by the projector. The picture appears most brilliant and life-like when you are seated near the projected beam.

Approximate Distances in Feet from Projector to Screen
(KODAK Projection Lenses)

Long Dimension of Projected Picture	126 Slides (28 x 28 mm)					135 Slides (24 x 36 mm)					110 Slides (13 x 17 mm) in 2 x 2-Inch Mounts or Adapters		
	3-inch* Lens	102 mm Lens	127 mm 124 mm* Lens	7-inch* Lens	102-152 mm 100-150 mm* Zoom Lens	3-inch* Lens	102 mm Lens	127 mm 124 mm* Lens	7-inch* Lens	102-152 mm 100-150 mm* Zoom Lens	2½-inch* Lens	3-inch* Lens	102 mm Lens
40"	10	13½	17	23½	13½ to 20	8	10½	13	18½	10½ to 16	14	16½	22
50"	12½	16½	21	29	16½ to 25	10	13	16½	23	13 to 19½	17	20½	27½
60"	15	20	25	34½	20 to 30	11½	15½	19½	27	15½ to 23½	20½	24½	33
70"	17½	23	29	40½	23 to 34½	13½	18	22½	31½	18 to 27	24	28½	38
84"	20½	27½	34½	48	27½ to 41½	16	21½	27	37½	21½ to 32	28½	34½	45½

*These lenses are recommended for slides mounted in glass. See page 21 for list of lenses.

KODAK Projection
EKTANAR C Zoom Lens,
102 to 152 mm f/3.5

KODAK Projection
EKTAGRAPHIC FF Zoom Lens,
100 to 150 mm f/3.5

If your projector is equipped with either of these optional zoom lenses, you can vary the size of the projected image to fill a screen without changing the projector-to-screen distance.

To use the zoom lens:

1. Install the zoom lens by moving the focus knob toward the top of the projector and guiding the lens into the projector. Insert the lens far enough into its recess so that the gear teeth on the lens barrel will be

engaged by the gear on the focus-knob shaft.

2. Rotate the focus knob until the projected image is sharp.
3. Rotate the front part of the lens barrel until the image fills the screen.
4. To obtain maximum image sharpness and the desired image size, you may need to repeat steps 2 and 3 alternately.

SLIDE TRAY

Furnished with your projector is the KODAK CAROUSEL TRANSVUE 140 Slide Tray. This tray is made of a translucent material which allows you to see the slide-identification numbers on the tray without turning on the room lights. It holds 140 slides in 2 x 2-inch cardboard or thin plastic mounts (*not* glass or metal mounts) up to $\frac{1}{16}$ inch thick. Since this tray was designed to hold as many slides as possible, the slide compartments in the tray are quite narrow. For this reason, your slide mounts should be in good condition. Mounts which are warped or bent may fail to drop from the tray into the projector. (If this happens, straighten the mount with your fingers or place the slide in a new mount, such as a KODAK READY-MOUNT.)

Clip off all mount corners that are frayed. Do not attempt to project slides mounted with loose or sticky tape.

As the tray revolves, the number of the slide being projected will be opposite the gate index on the projector.

(You can obtain additional slide trays from your dealer; see page 20.)

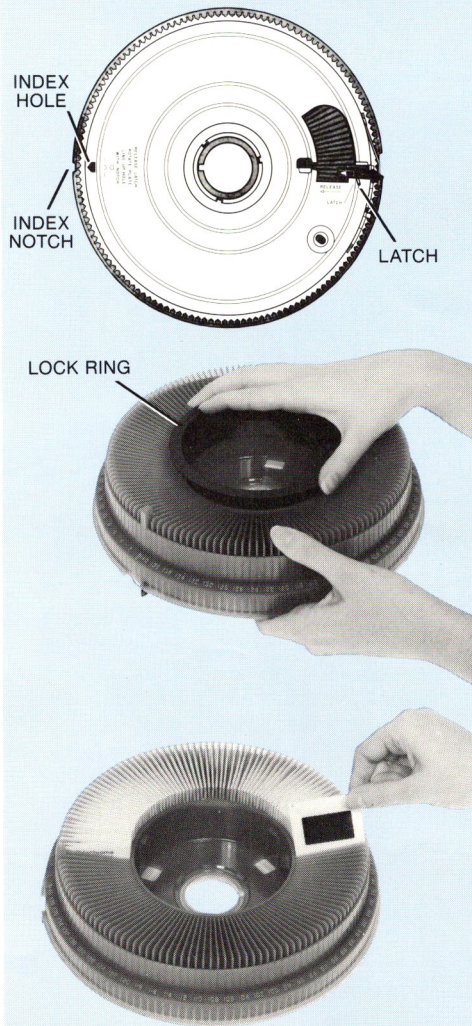

Loading Slide Tray

Check the bottom of the tray to make sure the INDEX HOLE is opposite the INDEX NOTCH. If it isn't, slide the LATCH in the direction shown by the arrow, and turn the bottom plate until the index hole points to the index notch. Then release the latch.

Remove the LOCK RING from the tray by turning the ring in the direction of the arrow marked UNLOCK; then lift off the ring. Insert a slide in each slot in the tray, with the top of the picture down. The printed border, or trademark side, of each cardboard-mounted slide—or emulsion (dull) surface of a slide mounted in plastic—should face the next lower number. For example, the bordered, trademark (or emulsion) side of slide No. 2 should face toward slide No. 1, No. 3 toward No. 2, etc.

Replace the lock ring, turning it in the direction of the arrow marked LOCK until the ring is secure on the tray.

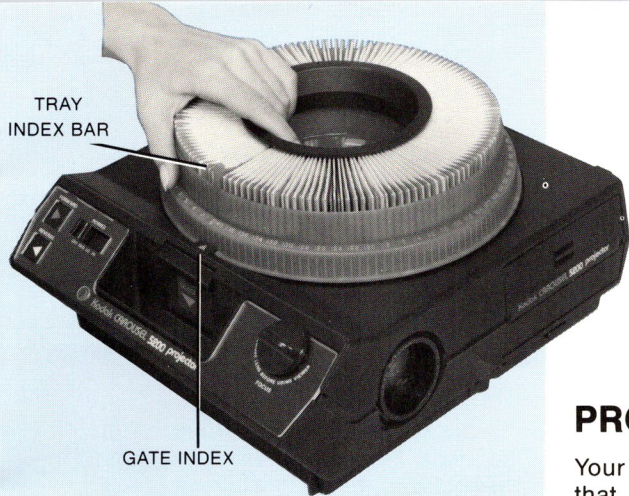

Placing Slide Tray on Projector

Place the loaded slide tray on the projector so that the hole in the center of the tray fits over the center post on the top of the projector. Then turn the tray slowly until the TRAY INDEX BAR is opposite the GATE INDEX on the projector. The tray will drop down into operating position on the projector. If the tray doesn't drop easily into place, check the alignment of the index hole and the index notch as described under "Loading Slide Tray" on page 8.

NOTE: The tray will drop farther down on the projector during the first slide-change cycle.

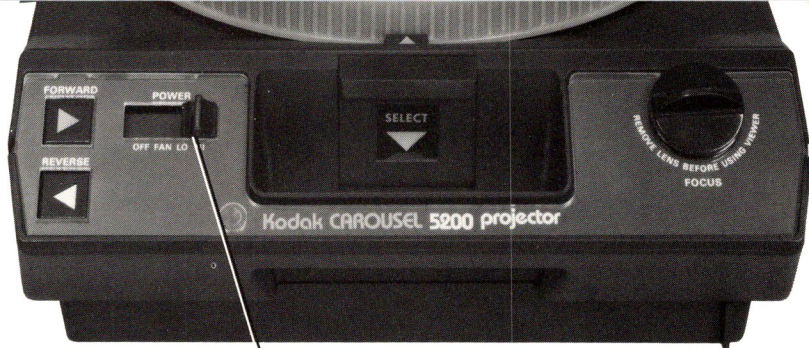

POWER SWITCH

PROJECTING SLIDES

Your projector has a built-in shutter that interrupts the projection beam when there is no slide in the projector gate. This eliminates the harsh glare of an illuminated white screen before the first slide in a tray, after the last slide in a tray, and during slide-tray changes. The illuminated control panel and built-in READING LIGHT will help you avoid the need of interrupting your slide show by turning on the room lights. To use the reading light, simply lift the cover.

Turn on the projection lamp by sliding the POWER SWITCH to HI (300-watt illumination) or LO (250-watt illumination). Briefly press the FORWARD BUTTON on the projector or the FOR (forward) button on the remote control to put the first slide in viewing position.

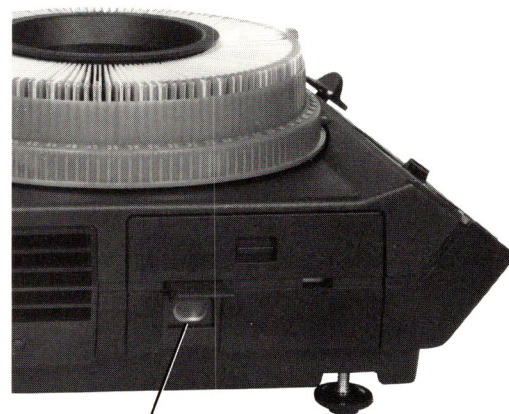

READING LIGHT



Elevation

To center the projected image on the screen vertically, elevate the front of the projector by using the ELEVATING FOOT. To release the foot, press the RELEASE while lifting the front of the projector to the desired height. Use the ELEVATING WHEEL for fine adjustments in elevation.

If the image is not aligned horizontally, make an adjustment with the LEVELING FOOT at the rear of the projector.

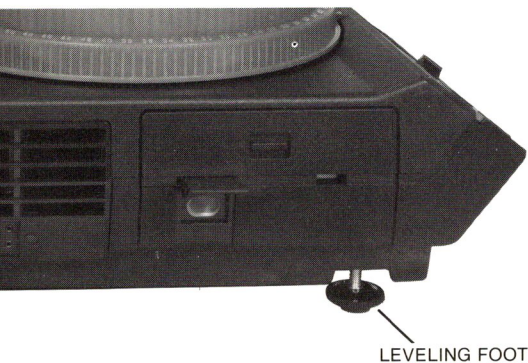

Forward and Reverse Buttons

FORWARD and REVERSE BUTTONS, located at the left side of the projector control panel, control the direction in which the tray rotates. Briefly press the forward or reverse button to change slides in the desired direction.

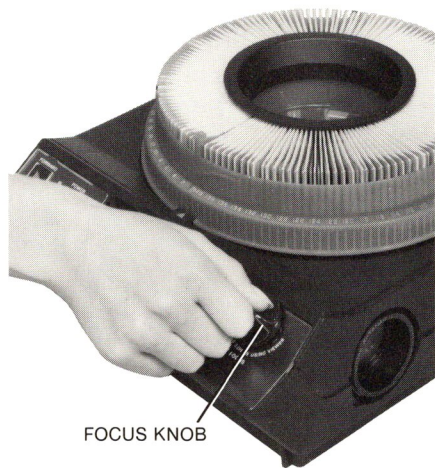

Focus

Let the projector warm up for about 30 seconds. Focus for maximum sharpness at the center of the screen image by rotating the FOCUS KNOB. *You will need to focus only the first picture if all slides are in the same type of mount.*

Under special conditions—for example, when you are projecting slides in intermixed types of slide mounts—you may need to readjust the focus manually.

To demonstrate extreme focus changes, place cardboard-mounted slides in the tray with every other slide in backwards. You can see the action of the automatic focus system by watching the movement of the focus knob or by watching the screen image.

NOTE: A matte-surface (write-on) slide or a mount without film can cause the focus motor to run continuously.

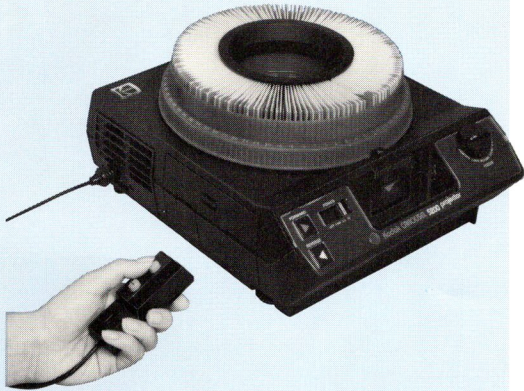

Remote Control

The remote control has both FOR (forward) and REV (reverse) buttons for controlling the direction in which the slide tray rotates. Press either the forward or the reverse button to change slides in the desired direction.

Random Selection of Slides in Trays

To project a particular slide in a tray:

1. Press the SELECT BAR and hold it down.
2. Rotate the tray in either direction until the number of the slide you want to project is opposite the gate index on the projector.
3. Release the select bar; the desired slide will be projected immediately.

Removing Slide Tray

You can remove the tray from the projector at any time—with the power switch turned off or on:

1. Press the SELECT BAR and hold it down. With the power switch in the OFF position, you will need to push the select bar *all the way down*.
2. Rotate the tray until the tray index bar is opposite the gate index.
3. Release the select bar and lift off the tray.

NOTE: When the projector power cord is not plugged in, the select bar will function manually only when the power switch is in the OFF position.



Showing Single Slides

1. With the projector turned on, insert a slide (correctly oriented) into the projector gate. Push the slide down into the gate as far as it will go.
2. After viewing the slide, press the SELECT BAR to eject the slide from the gate. You can then insert another slide into the gate. You can project slides up to 1/8 inch thick by this method.

After the Show

Slide the power switch to OFF and remove the slide tray.

Then, if you've been using the built-in viewer:

1. Slide the viewer back into the projector as described on page 6.
2. Replace the projection lens in the projector as described on page 13.

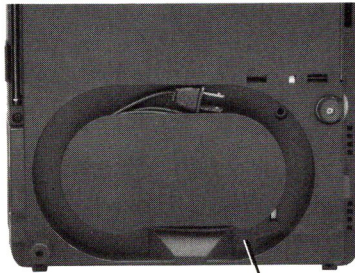

CORD RETAINER

Or if you've been projecting slides on a large screen:

1. **As you support the front of the projector**, release the elevating foot by pressing the release. Then lower the front of the projector; the elevating foot will be retracted into the projector.
2. Retract the leveling foot.
3. Retract the lens by turning the focus knob counterclockwise.

Then unplug the power and remote-control cords. Wind the power cord around the CORD RETAINER on the underside of the projector. Fold the remote-control cord by placing the ends together and folding it in about 4-inch lengths. Then place it in the cord compartment.

PROJECTOR CARE

Your CAROUSEL Projector requires *no* lubrication; all bearings are self-lubricating.

Projection-Lamp Replacement

Your projector is equipped with a code FHS projection lamp with a rated life of 70 hours. There are also two special-application lamps available. For longer lamp life (but less brightness), use a code EXY lamp with a rated life of 200 hours. For 25 percent greater brightness than offered by the FHS lamp, use a code EXR lamp with a rated life of 35 hours. Use of high-brightness lamps may cause some buckling or premature fading of your slides.

All the lamp-life ratings given above are for projectors with the power switch set at HI. Lamp life can be extended by as much as 3 times by using the LO setting.

It's a good idea to keep a spare projection lamp on hand. If the lamp should burn out during use, set the power switch at FAN to speed cooling. When the projector and lamp have cooled sufficiently, turn the projector

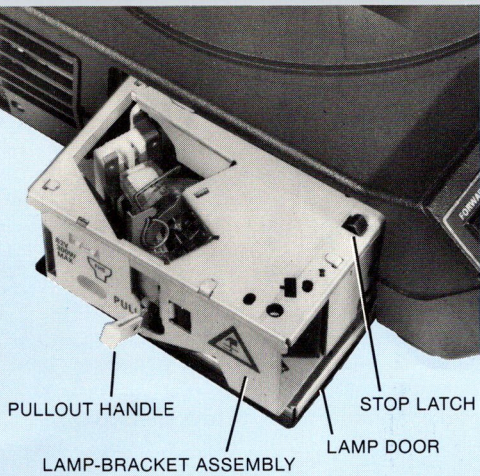

PULLOUT HANDLE
LAMP-BRACKET ASSEMBLY
STOP LATCH
LAMP DOOR

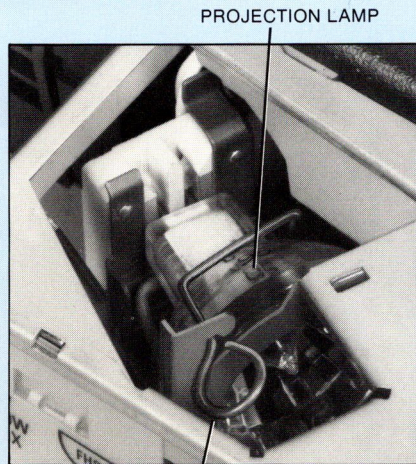

PROJECTION LAMP
LAMP-RELEASE LEVER

off and unplug the power cord.

Open the LAMP DOOR by pressing down on the latch. Grasp the small PULLOUT HANDLE on the LAMP-BRACKET ASSEMBLY, and pull it away from the projector to the stop position.

CAUTION: Be certain that the projector and the projection lamp have cooled before you remove the lamp.

Push the LAMP-RELEASE LEVER down and to the side until it is free of its retaining clip; then raise the lever all the way, grasp the lamp, and remove it.

Insert a new lamp into the socket with a prong of the lamp in each slot of the socket. *Do not touch the transparent portion of the lamp. If you accidentally get fingerprints on the lamp, wipe it carefully with a clean, soft cloth moistened with rubbing alcohol.* Lower the lamp-release lever to seat the lamp; then push down on the lever and slide it under its retaining clip. With your forefinger, press down firmly on the reflector base of the lamp to be sure that the lamp is correctly seated.

Push the lamp-bracket assembly all the way back into the projector. Then close the lamp door.

Cleaning

To get the brightest, sharpest screen images, keep the optical system of your projector clean. Dust or fingerprints on the projection or condenser lens will reduce the brightness of the screen image and will cause it to appear unsharp or low in contrast.

Projection lens

Turn the focus knob clockwise until the lens is out as far as it will go. Carefully move the focus knob toward the top of the projector as you withdraw the projection lens. Blow any dust or dirt from the lens.

With paper such as KODAK Lens Cleaning Paper or a soft, clean, lintless cloth, gently wipe the front and rear surfaces of the lens. If moisture is required, breathe on the lens surface or use a drop of cleaner such as KODAK Lens Cleaner on the paper or cloth.

Replace the lens by again moving the focus knob toward the top of the projector and guiding the lens back into position. Insert the lens far enough into its recess so that the gear teeth on the side of the lens barrel will be engaged by the gear on the focus-knob shaft.

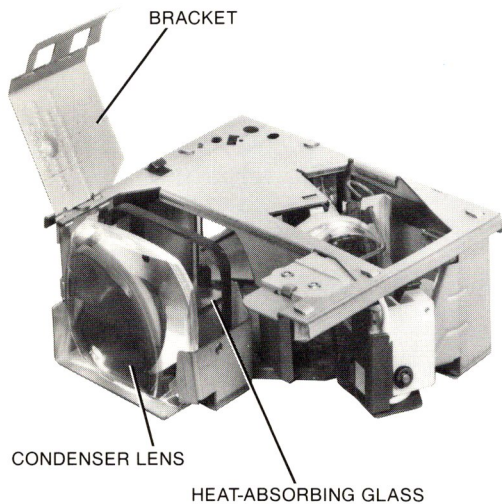

Condenser lens, heat-absorbing glass, and mirror

CAUTION: The heat-absorbing glass may shatter. Handle it only with gloves. Keep the glass covered with a cloth or other material while it is out of the projector.

Open the LAMP DOOR. Remove the entire lamp-bracket assembly by pulling the assembly straight back out of the projector as you push down on the STOP LATCH (page 13). Unscrew the small retaining screw, and raise the hinged BRACKET. Then *carefully* lift out the CONDENSER LENS and the HEAT-ABSORBING GLASS, and *gently* place them on a soft cloth.

Clean both sides of the condenser lens and the heat-absorbing glass with paper such as KODAK Lens Cleaning Paper or a soft, clean, lintless cloth. Be careful not to leave fingerprints on any of the surfaces. Replace the lens and the heat-absorbing glass in their original locations. Lower the bracket and securely tighten the retaining screw.

Turn the entire lamp-bracket assembly upside down so that you can reach the mirror through the opening in the underside. Gently clean the surface of the mirror with KODAK Lens

Cleaning Paper or a soft, clean, lintless cloth moistened with KODAK Lens Cleaner. Then replace the assembly in the projector and close the lamp door.

Thermal Fuses

Your projector is equipped with thermal fuses to prevent overheating and possible damage to the projector in case of exhaust-fan or motor failure. If overheating causes the fuses to open, the projector will not operate. The projector will require factory or repair-facility attention to make it run again. Refer to the Service Centers at the back of this manual.

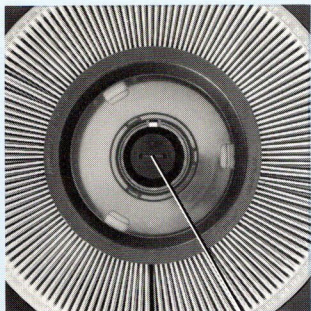

TRAY-REMOVAL SCREW

Emergency Slide-Tray Removal

If the slide-changing mechanism becomes inoperative because of a defective slide (see page 8), a foreign object, etc, turn the coin-slotted TRAY-REMOVAL SCREW in either direction, as far as it will go, to retract the tray lock. While holding the screw in this position, lift off the tray. When you remove the tray in this manner, turn the tray upside down and realign the index notch as described on page 8; then set the tray to one side. Remove the defective slide from the projector by actuating the forward button, or if necessary, pull the slide or foreign object from the gate by hand. Replace the tray on the projector.

PROJECTION TIPS

Long-Run Applications

Allow for unrestricted flow of air through the projector openings. If you use the projector in a window display or in a cabinet, provide an adequate outlet for the warm air expelled from the rear grille vent. The air circulating through the projector should be as dust-free as possible.

Editing Slides

If you want to edit your slides, you can project them singly, as described on page 11. Or you can place a tray of slides on the projector. Remove the lock ring from the tray. To edit a slide after viewing, firmly press and hold down the select bar, and remove the slide from the tray. You can then reorient the slide or replace it with another.

The optional KODAK EC Stack Loader, described on page 20, provides a convenient means of editing your slides. Using the built-in viewer is a quick and easy way to set up for editing.

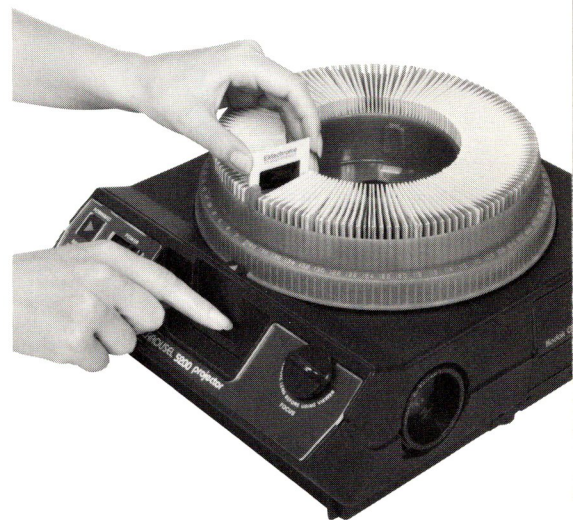

SERVICE FOR YOUR PROJECTOR

If you have questions about your projector or have difficulty using it, carefully reread the section of this manual which pertains to the questions you have. *Especially* be sure to consult the Troubleshooting Guide on page 17. Since some projectors which are returned for repair do not need service, please review this information carefully.

If you believe your projector does need service—take your projector to your photo dealer.

OR

Take your projector to a Kodak Consumer Center if one is located near you. The addresses are listed on pages 18 and 19.

OR

Send a letter describing the problem to Eastman Kodak Company, Department 841S, 343 State Street, Rochester, New York 14650. Be sure to specify the model of your projector.

If your projector does require repair, you may send it through your photo dealer or directly to one of our Equipment Service Centers, listed on the back cover.

Packing Instructions

1. Include a note with your projector giving all details: date and place of purchase and a description of the problem.
2. Use a sturdy carton that is large enough for you to surround the projector completely with packaging material, such as crumpled newspaper.
3. Securely fasten the carton with tape. Clearly write the address of the Equipment Service Center and your name and address on the top and bottom of the carton.
4. Mail the carton to Kodak. Remember to insure the equipment to replacement value.

Troubleshooting Guide

Important: So that you won't be without your projector unnecessarily, please consult this guide **before** requesting service.

WHAT HAPPENED	PROBABLE CAUSE	CORRECTION
Projector doesn't operate.	No power to projector.	Plug power cord into suitable electrical outlet. Set power switch on LO or HI.
No illumination on screen with slide in projector gate.	Power switch on OFF or FAN.	Set switch on LO or HI.
	No lamp in projector.	Install lamp; see page 12.
	Lamp burned out.	Install new lamp; see page 12.
	Lamp not seated in socket. Lamp door not closed.	Check lamp; see page 12. Close lamp door.
Slide not in proper focus on screen.	Slide itself not sharp.	Examine slide for proper focus.
	First slide in tray not properly focused manually.	Focus center of first slide manually; see page 10.
	Slide in different type of mount from others.	Focus manually; see page 10.
	Projection lens installed improperly.	Follow instructions for replacing lens on page 13.

WHAT HAPPENED	PROBABLE CAUSE	CORRECTION
Slide fails to drop into projection position.	Tray base plate not properly indexed.	Align index hole and index notch; see page 8.
	Tray not properly positioned on projector. Slide mount warped or frayed at corners.	Position tray on projector as described on page 9. Straighten mount or remount slide; see page 8.
Uneven illumination on screen.	Projection lamp not fully seated.	Check lamp; see page 13.
	Condenser lens not installed or not positioned properly in mount.	Check condenser lens; see page 14.
	Slide mount not properly seated in projector gate.	Check slide position and slide-mount condition.
Projector won't cycle to next slide.	Tray not properly positioned.	Position tray as described on page 9.
	Slide or foreign object stuck in tray or gate.	Check tray. If necessary, see "Emergency Slide-Tray Removal" on page 15.

Kodak Consumer Centers

Kodak Consumer Centers offer photographic information on Kodak equipment and film. Also, the centers can perform minor adjustments on Kodak amateur equipment. The centers will advise you on the nature of serious problems and the cost of repairs which may be necessary. Addresses and telephone numbers may change. For up-to-date information, consult the Yellow Pages of your telephone directory under "Photographic Equipment and Supplies."

ALABAMA

720 S. 37th Street
Birmingham 35222
(205) 322-2401

CALIFORNIA

1017 N. Las Palmas Avenue
Los Angeles 90038
(213) 465-7151

925 Page Mill Road
Palo Alto 94304
(San Francisco area)
(415) 493-7200

3250 Van Ness Avenue
San Francisco 94109
(415) 928-1300

9100 Alcosta Boulevard
San Ramon 94583
(San Francisco area)
(415) 828-7000

12100 Rivera Road
Whittier 90606
(Los Angeles area)
(213) 685-5610

COLORADO

1 Inverness Drive East
Englewood 80112
(Denver area)
(303) 779-3324

FLORIDA

1001 Ponce de Leon Boulevard
Coral Gables 33134
(Miami area)
(305) 445-0511
2715 Atlantic Boulevard
Jacksonville 32207
(904) 399-4430

GEORGIA

5315 Peachtree Industrial Boulevard
Chamblee 30341
(Atlanta area)
(404) 455-0123

HAWAII

1065 Kapiolani Boulevard
Honolulu 96814
(808) 531-6565
1122 Mapunapuna Street
Honolulu 96819
(808) 833-1661

ILLINOIS

1901 West 22nd Street
Oak Brook 60521
(Chicago area)
(312) 654-5542

INDIANA

4760 Kingsway Drive
Indianapolis 46205
(317) 251-3159

KANSAS

7301 Frontage Road, Interstate 35
Shawnee Mission 66204
(Kansas City area)
(913) 831-4020

LOUISIANA

Pontchartrain Bldg., Suite 100
3939 N. Causeway Blvd.
Metairie 70002
(New Orleans area)
(504) 837-3566

MARYLAND

7115 Ambassador Road
Baltimore 21207
(301) 265-5400

MASSACHUSETTS

480 Cochituate Road
Framingham 01701
(Boston area)
(617) 875-0979

MICHIGAN

21600 Greenfield Road
Oak Park 48237
(Detroit area)
(313) 967-1600

MINNESOTA

2412 Nicollet Avenue
Minneapolis 55404
(612) 870-3456

MISSOURI

1853 Craig Road
St. Louis 63141
(314) 434-4330

NEBRASKA

7262 Mercy Road
Omaha 68124
(402) 393-4000

NEW JERSEY

P.O. Box 1334, Route 130
Dayton 08810
(212) 879-1500 and (201) 329-6600
16-31 Route 208
Fair Lawn 07410
(201) 797-0600

NEW YORK

1133 Avenue of the Americas
New York City 10036
(212) 930-7565

800 Lee Road
Rochester 14650
(716) 722-0670

NORTH CAROLINA

77 Executive Center
Bldg. 5311, Suite 80
Charlotte 28210
(704) 525-5090

OHIO

14 Knollcrest Drive
Cincinnati 45237
(513) 948-5728
4545 West 160th Street
Cleveland 44135
(216) 267-0300

OKLAHOMA

3015 United Founders Boulevard
Oklahoma City 73112
(405) 848-7803

OREGON

5410 S.W. Macadam Avenue
Portland 97201
(503) 222-3831

PENNSYLVANIA

425 Maryland Drive
Ft. Washington 19034
(Philadelphia area)
(215) 242-3200
2857 Banksville Road
Pittsburgh 15216
(412) 563-6733

TENNESSEE

2225 Union Avenue
Memphis 38104
(901) 278-5900

TEXAS

2800 Forest Lane
Dallas 75234
(214) 241-1611
610 Gray
Houston 77002
(713) 820-7711
5815 Callaghan Road
Suite 112
San Antonio 78228
(512) 684-5934

UTAH

University Club Building
Suite 100
136 East South Temple Street
Salt Lake City 84111
(801) 363-5713

VIRGINIA

1555 Wilson Blvd.
Arlington 22209
(Washington, D.C. area)
(703) 527-2000

WASHINGTON

9675 Sunset Highway
Mercer Island 98040
(Seattle area)
(206) 232-7770

AUXILIARY EQUIPMENT



KODAK Projection Screen (40 x 40 inches)

Designed for use at home with your projector. The KODAK Projection Screen is made of mildew-resistant fabric with a highly reflective glass-beaded surface for bright screen images. The screen has easy-opening legs and can be adjusted for overall height from the floor.



KODAK CAROUSEL Slide Tray

Additional slide trays to accommodate 80 or 140 slides, supplied in attractive bookshelf-type storage boxes, are available from your dealer. Each box contains an identification card and tray sticker.

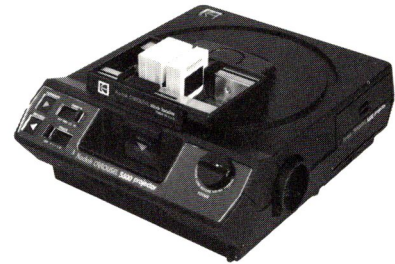

KODAK EC Stack Loader

Lets you project and edit up to forty 2 x 2-inch slides in cardboard or very thin plastic mounts (or up to thirty 110 slides in 2 x 2 adapters) without loading them into a tray.



KODAK Projection Lenses (3)

(Curved-field lenses for slides mounted in cardboard or other non-glass mounts)

KODAK Projection EKTANAR C Lens, 102 mm *f*/2.8

KODAK Projection EKTANAR C Lens, 127 mm *f*/2.8

KODAK Projection EKTANAR C Zoom Lens, 102 to 152 mm *f*/3.5



KODAK Projection Lenses (6)

KODAK Projection EKTANAR Lens, 2½-inch *f*/3.5 (recommended only for 110 slides in 2 x 2-inch mounts or adapters)

KODAK Projection EKTANAR Lens, 3-inch *f*/3.5

KODAK Projection EKTAGRAPHIC FF Lens, 102 mm *f*/2.8

KODAK Projection EKTAGRAPHIC FF Lens, 124 mm *f*/2.8

KODAK Projection EKTANON Lens, 7-inch *f*/3.5

KODAK Projection EKTAGRAPHIC FF Zoom Lens, 100 to 150 mm *f*/3.5



KODAK EC Projector Dust Cover

This attractive tinted dust cover protects your projector from dust and dirt while you're not showing slides. It snaps firmly into place when you press on the center of the cover and is easily removed by means of a sliding latch.

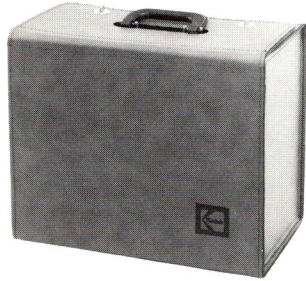

**KODAK CAROUSEL Projector Case,
Model E**

This lined compartment case accommodates your projector, a slide tray in its carton, and such Kodak accessories as a stack loader, slide clip set, zoom lens, spare lamp, or extension cords. It is constructed of nylon-stitched brown simulated leather with panels that are reinforced with ebony board. All hardware is brass-finished.

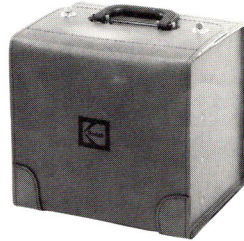

KODAK CAROUSEL Slide Tray Case

This handsome case will accommodate three slide trays or a lesser number with room for your miscellaneous equipment.

It is a matching case to the KODAK CAROUSEL Projector Case, Model E.

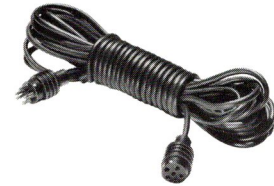

**KODAK EC Remote Extension Cord,
25-foot**

Extends the range of the 12-foot remote-control cord so that you can operate the projector from a location near the screen. Up to 4 extension cords can be added to accommodate most projection distances.

KODAK 2 x 2 Adapter for 110 Slides

If you have slides that are in 30 x 30 mm mounts, snap each slide into an adapter for projection with your CAROUSEL Projector. Project the slides singly, in trays, or with the optional KODAK EC Stack Loader. Adapters are supplied in boxes of 20.

**KODAK Slide Clip
(for KODAK EC Stack Loader)**

Makes handling stacks of slides easier than ever—no loose slides to slip out of your hands! Each clip holds up to 36 slides in cardboard or plastic mounts up to .050 inch (1.27 mm) thick, or up to 25 slides in 2 x 2 adapters for 110 slides. The label on each clip provides space for slide identification.

A set of 12 clips provides compact, low-cost storage for up to 432 slides in an attractive book-shelf-type storage box.

**KODAK EC Sound-Slide
Synchronizer**

This unit permits you to use a stereo record/playback tape recorder that is equipped with an external speaker jack as a programmer with your projector.

Other special-purpose accessories are available for use with your CAROUSEL Projector. See your photo dealer.

FULL ONE-YEAR WARRANTY

This Kodak projector is warranted by Kodak to function properly for one year from the date of purchase. This warranty does not cover the projection lamp. Kodak makes no other express warranty for this projector. This warranty gives you specific legal rights, and you may also have other rights which vary from state to state.

Carefully read and follow the instructions in the manual to get good results and prevent damage to your projector.

If this Kodak projector does not function properly within one year after purchase, Kodak will repair it without charge. If Kodak is unable to repair it, the option of replacement or refund of the purchase price will be available. These remedies are not available if the projector is damaged by misuse or other circumstances beyond Kodak's control, or if the improper functioning of the projector is caused by failure to follow the care and operating instructions in the manual.

Repair, and the option of replacement or refund in the event that Kodak is unable to repair the projector, are Kodak's only obligations. Kodak will not be responsible for any consequential or incidental damages resulting from the sale or use of this projector, even if loss or damage is caused by the negligence or other fault of Kodak. (Some states do not allow the exclusion or limitation of incidental or consequential damages, so the above limitation or exclusion may not apply to you.)

For assistance in using this projector, contact a dealer in Kodak products or one of the Kodak Consumer Centers located in the United States. For service on this projector, return it through a dealer in Kodak products, one of the Kodak Equipment Service Centers listed here, or a Kodak Consumer Center. Enclosing a note with the projector giving details of the problem and date of purchase will help Kodak return the projector promptly.

SERVICE CENTERS

If your Kodak projector should require service, complete facilities are provided at the following Kodak Equipment Service Centers. For fastest service, send your projector to the Service Center nearest you.

9100 Alcosta Blvd., San Ramon, California 94583
12100 Rivera Road, Whittier, California 90606
5315 Peachtree Industrial Blvd., Chamblee, Georgia 30341
1122 Mapunapuna Street, Honolulu, Hawaii 96819
1901 West 22nd Street, Oak Brook, Illinois 60521
Route 130, P.O. Box 1334, Dayton, New Jersey 08810
800 Lee Road, Rochester, New York 14650
2800 Forest Lane, Dallas, Texas 75234



Consumer/Professional & Finishing Markets

Rochester, New York 14650

11-80-BE
Pt. No. 634631

Printed in U.S.A.

KODAK, CAROUSEL, EKTANAR, EKTAGRAPHIC, EKTANON, TRANSVUE, and READY-MOUNT are trademarks.