

RICOH

XR-P

MULTI-PROGRAM



Nomenclature.....	3
Attaching finder cap and strap.....	4
Mount the lens.....	5
Set lens at "P".....	7
Insert batteries.....	8
Check batteries.....	9
Insert the film.....	10
Set the film speed.....	12
Hold your camera properly.....	13
Program AE photography.....	14
Focusing.....	16
Rewind the film.....	17
Self-timer photography.....	18
Programmed flash photography.....	20
How to use multi-program.....	23
Aperture-priority AE.....	25
Shutter bias program AE.....	26
Manual photography.....	27
TV mode.....	28
Exposure compensation.....	30
AE lock.....	31
With Ricoh flash other than 300P.....	32
With non-dedicated flash.....	33
Flash in daylight.....	34
Aperture-priority flash.....	35
Depth of field.....	36
Bulb setting.....	37
Multiple exposure.....	38
Interval timer.....	39
Viewfinder lighting.....	40
Power on-off switch.....	40
Memo holder.....	41
Infrared mark.....	41
Accessories.....	42
Care of batteries.....	45
Storage of camera.....	46
Specifications.....	47

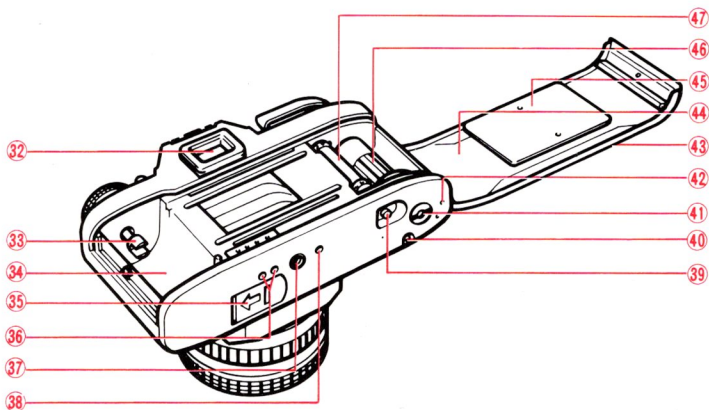
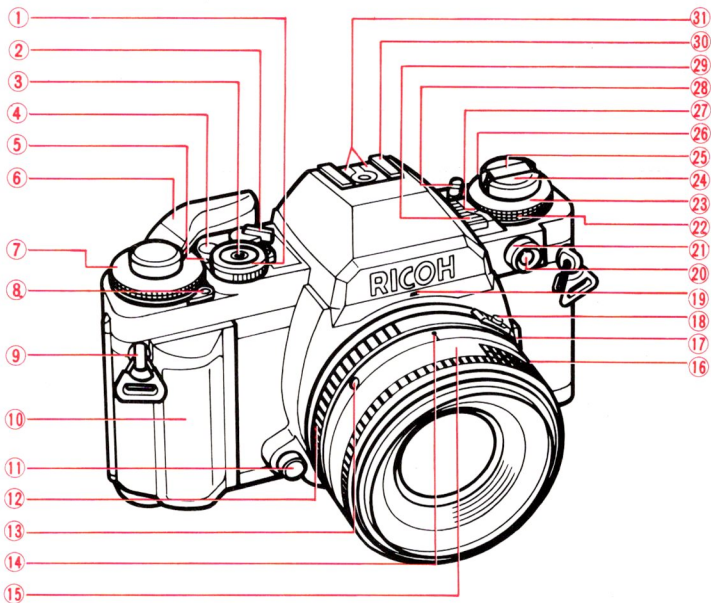

NOMENCLATURE

1. Program Selector
2. Power ON-OFF Switch
3. Shutter Release Button
4. Exposure Counter
5. Shutter Speed Index Line
6. Film Advance Lever
7. Shutter Speed Dial
8. Multiple Exposure (ME) Lever
9. Strap Eyelet
10. Removable Hand Grip
11. Lens Release Button
12. F-Stop Ring
13. Lens Locator Mounting Node
14. Depth of Field Scale
15. Focusing Ring
16. Flash Synchro Terminal
17. AE Lock/Illuminator Button
18. P Lock Button
19. Aperture Relay port
20. Self/Interval Timer Button
21. Self/Interval Timer
22. Film Speed Dial
23. Exposure Compensation Dial
24. Film Rewind Knob/Back Cover
Lock Release
25. Film Rewind Crank
26. Film Speed Index Line
27. Exposure Compensation Index
Line
28. Beep Switch
29. Illuminating Window
30. Hot Shoe
31. Flash Control Contacts
32. Viewfinder Eyepiece
33. Film Rewind Shaft
34. Film Chamber
35. Battery Compartment Cover
36. Motor Drive Contacts
37. Tripod Socket
38. Winder Contact
39. Film Rewind Release Button
40. Hand Grip Release Button
41. Winder/Motor Drive Coupler
42. Winder Positioning Hole
43. Memo Holder
44. Back Cover
45. Film Pressure Plate
46. Film Take-up Spool
47. Sprocket

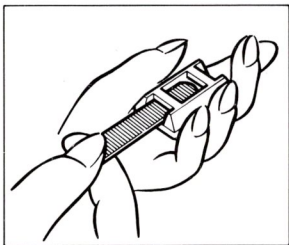
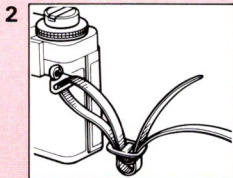
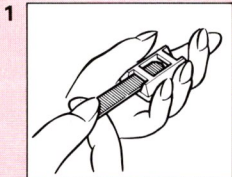

Fig. 1

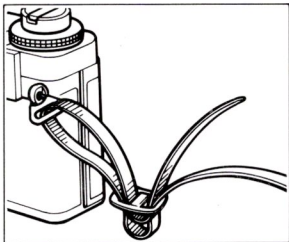

Fig. 2

ATTACHING THE VIEWFINDER CAP AND STRAP

1. Slip the Viewfinder Cap on to the strap. (**Fig. 1**)
2. Run the strap through the strap lug until the strap protrudes about 3 cm from the lug. Then adjust the strap length as desired. (**Fig. 2**)

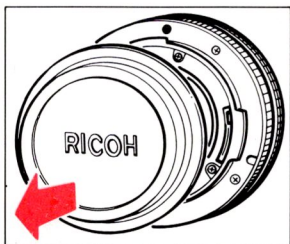
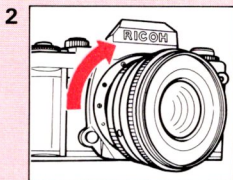
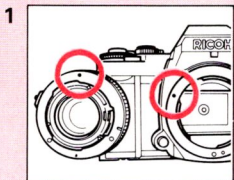

Fig. 3

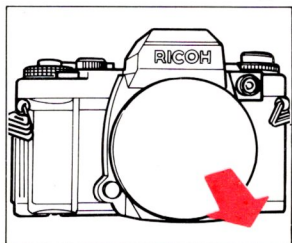

Fig. 4

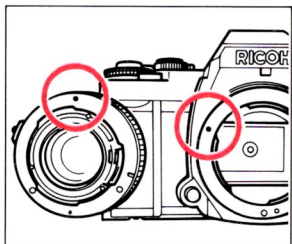

Fig. 5

MOUNT THE LENS

1. Pull the back lens cap to remove it from the lens. (Fig. 3)
2. Pull off the body cap. (Fig. 4)
3. Align the red dot on the camera with the red dot on the lens and mount the lens on the camera. (Fig. 5)

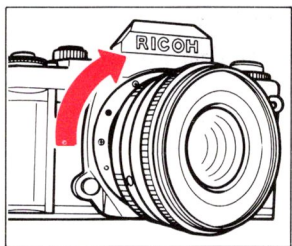

Fig. 6

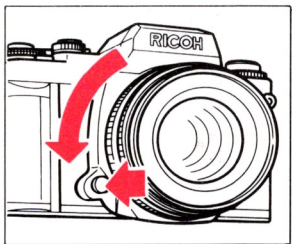

Fig. 7

4. Turn the lens in the arrow direction until it clicks into place. (Fig. 6)

★ To remove the lens, turn the lens in the arrow direction with the Lens Release Button depressed. (Fig. 7)

★ The conventional K mount lens can be used as aperture-priority and manual but cannot be used for programmed AE photography.

★ Proper performance of camera may not always be guaranteed with lenses other than Ricoh. For best results, use a Ricoh original equipment lens.

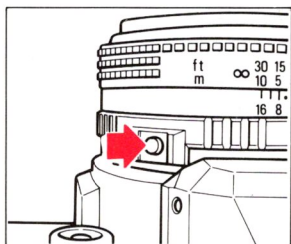
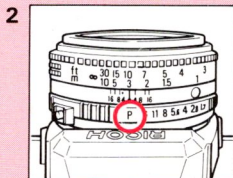
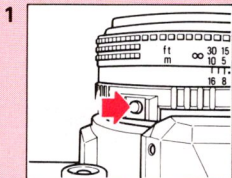

Fig. 8

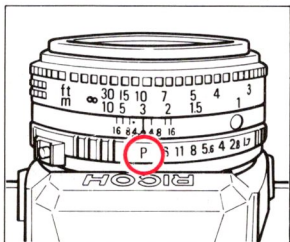

Fig. 9

SET LENS AT "P" POSITION

1. Turn the F-Stop Ring while P Lock Button is pressed. (Fig. 8)
 2. Set it to the locking "P" position as shown for programmed automatic exposure photography. (Fig. 9)
- ★ To unlock "P", turn the F-Stop Ring while P Lock Button is depressed.

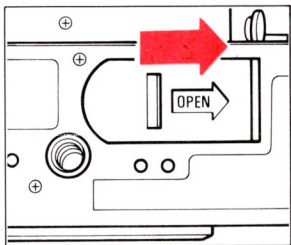
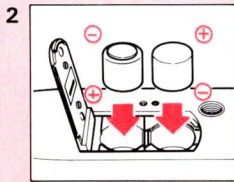
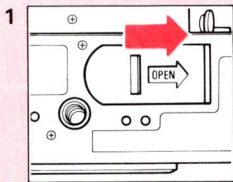

Fig. 10

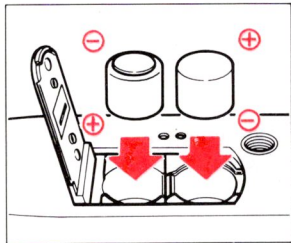

Fig. 11

INSERT BATTERIES

1. Slide the Battery Compartment Cover in the arrow direction with your fingernail to open. (Fig. 10)
2. Place batteries in the battery compartment according to (+) and (-) shown inside the battery compartment and close the compartment cover. (Fig. 11)

Batteries for use

- Four alkaline 1.5V batteries (LR44): Lasting about six months under normal use.
- Four silver oxide 1.55V batteries (SR44): Lasting about one year under normal use.
- Two lithium 3V batteries (CR-1/3N): Lasting about one year under normal use.

★ Refer to "CARE OF BATTERIES" also.

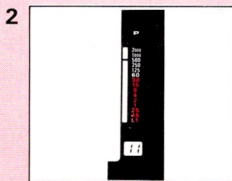
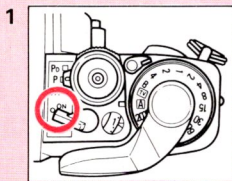

CHECK CONDITION OF BATTERIES

1. Turn the Power ON-OFF Switch ON. (Fig. 12)

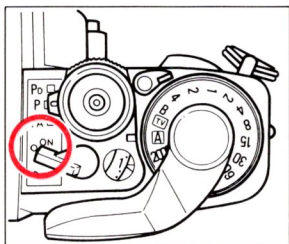

Fig. 12



Fig. 13

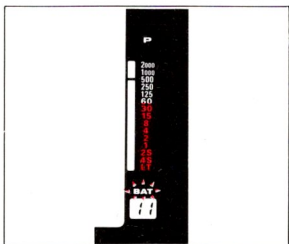

Fig. 14

2. Batteries are in good condition, when a liquid crystal display such as a Shutter Speed Indicator appears in the finder. (Fig. 13)

- ★ The BAT (battery low warning) blinks in the finder to warn against their failure when capacity of batteries drops below proper operating level. Change batteries as soon as possible. (Fig. 14)

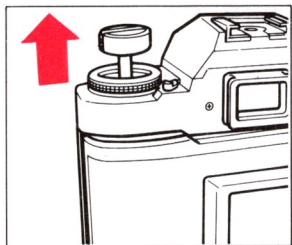
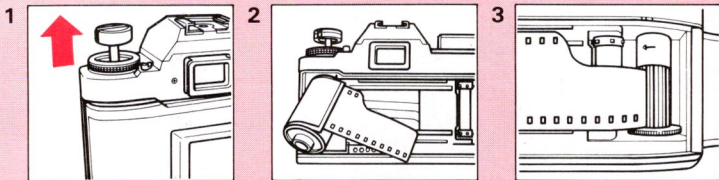

Fig. 15

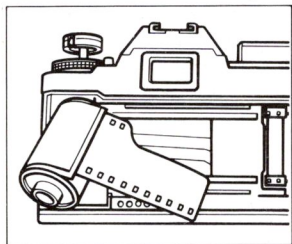

Fig. 16

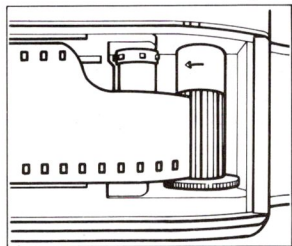

Fig. 17

INSERT THE FILM

(Do not expose the film to direct sunlight when inserting the film.)

1. Pull up the Film Rewind Knob until the Back Cover snaps open. (Fig. 15)
2. Insert the film in the Film Chamber and push the Film Rewind Knob down to the original position. You may have to rotate the knob slightly to push it down completely. (Fig. 16)
3. Insert the film leader in the slit on the Film Take-up Spool. (Fig. 17)

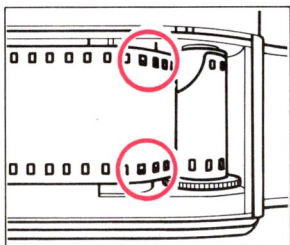
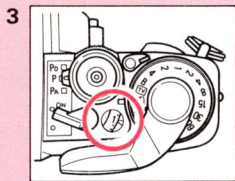
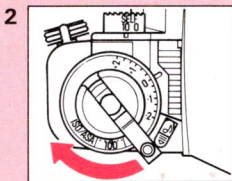
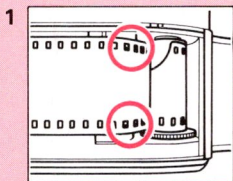

Fig. 18

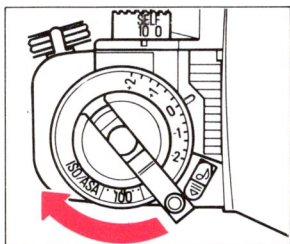

Fig. 19

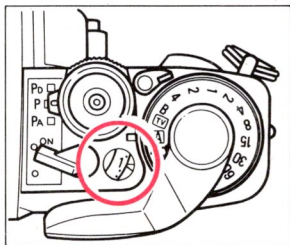

Fig. 20

4. Advance the Film Advance Lever to wind the film round the Film Take-up Spool. Check that the sprocket holes on the film are fully engaged on the Sprocket Teeth. (Fig. 18)

5. Close the Back Cover, unfold the Film Rewind Crank and turn it gently in the arrow direction until any slack is taken up. (Fig. 19)

6. Advance the film and press the Shutter Release Button a few times until "1" appears in the Exposure Counter. The film is properly advanced if the Film Rewind Knob rotates when the Film Advance Lever is stroked to advance the film. (Fig. 20)

- ★ When inserting the film in a cold place, the film leader may be hard and become brittle. Warm the film leader with your hand in such conditions.
- ★ 1/125 second shutter speed is automatically selected until "1" appears in the Exposure Counter. This is a convenient device that prevents a long shutter speed when film loading with the lens cap on.

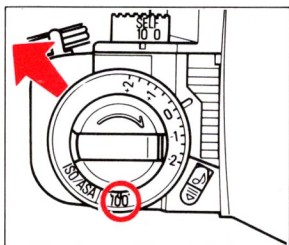
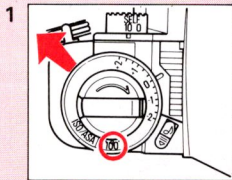

Fig. 21

SET THE FILM SPEED

1. The film speed (ISO/ASA) shown on the film package must be set to the Film Speed Index Line.
2. Pull the Film Speed Dial and turn it to set to the index. (Fig. 21)

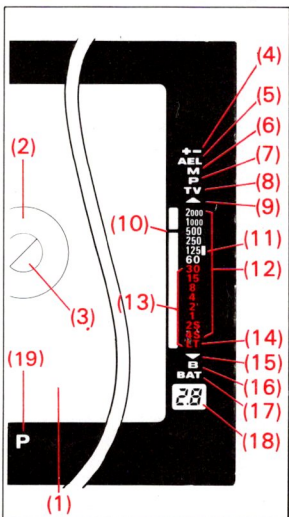

Fig. 22

INDICATIONS IN VIEWFINDER

- (1) Matte Surface
- (2) Microprism Band
- (3) Split-image Spot
- (4) Exposure Adjustment
- (5) AE Lock
- (6) Manual
- (7) Program Mode
- (8) TV Mode
- (9) Overexposure
- (10) Shutter Speed Indicator
- (11) Flash Ready/Correct Auto Flash Indicator
- (12) Shutter Speeds
- (13) Slow Shutter Speed Range
- (14) Long Time Exposure
- (15) Underexposure
- (16) Bulb
- (17) Battery Low Warning Signal
- (18) Programmed F-Stop Number
- (19) Aperture Setting



Fig. 23

HOW TO HOLD YOUR CAMERA (Good position for photography)

- (1) Lightly put your right-hand forefinger on the Shutter Release Button and hold the camera body with other fingers.
 - (2) Make your right arm comfortable.
 - (3) Cradle your camera in your left hand and hold it so that the Focusing Ring can be easily turned with fingers.
 - (4) Brace your left elbow to your body and put the camera to your face. Look through the viewfinder to compose your picture. **(Fig. 23)**
- ★ It is important to practice correct shooting position to avoid blurred or tilted pictures.

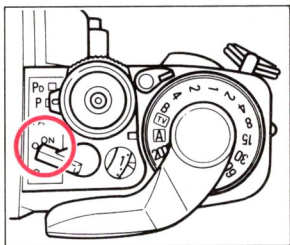
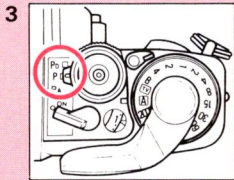
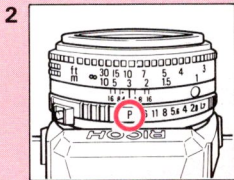
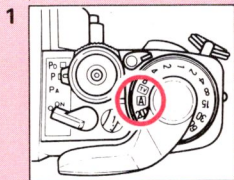

Fig. 24

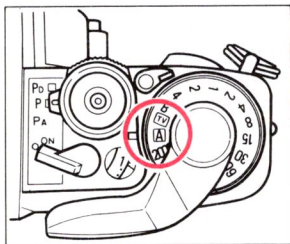

Fig. 25

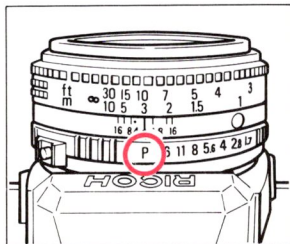

Fig. 26

PROGRAM AE PHOTOGRAPHY

In program AE photography, the camera automatically selects the f-stop number and the shutter speed according to subject illumination. Programs are best for general photos of figures or scenery. Special-effects shooting etc., can be done using the XR-P's multitude of override options. Please keep in mind however that for most shooting you can just focus and snap.

1. Turn the Power ON-OFF Switch ON. (Fig. 24)
2. Set the Shutter Speed Dial to "A". (Fig. 25)
3. Set the lens to "P". (Fig. 26)

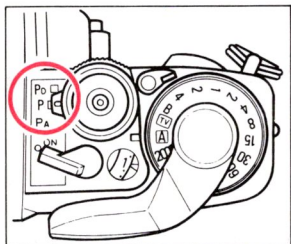
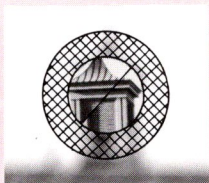

Fig. 27

4. Set the Program Selector to "P". (Normal Program Setting) (Fig. 27)
 - ★● PA (Action Program Setting) is used for taking fast moving subjects as in sports photography.
 - PD (Depth Program Setting) is used for scenery pictures or close-up shots which will bring both the foreground and background into sharpest possible focus.
 - P (Normal Program Setting) is used for general snap shots.
 - ★ Refer to "Applications" for other shooting modes.
 - ★ Refer to "Applications" for further details.
5. Look through the viewfinder and turn the Focusing Ring to focus. You can focus either by using the Split Image or Microprism.



2

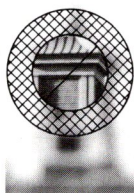
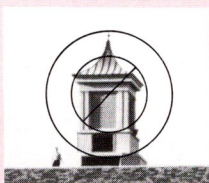

Fig. 28

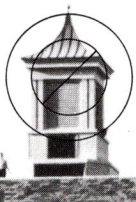

Fig. 29

FOCUSING (Fig. 28, 29)

Split image Focusing

When the split images in the Split-Image Spot form a single, clear image, the subject is in focus.

Microprism Focusing

When the subject loses its "shimmering" effect and becomes very sharp, the subject is in focus.

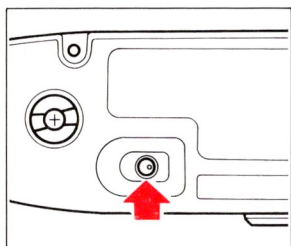
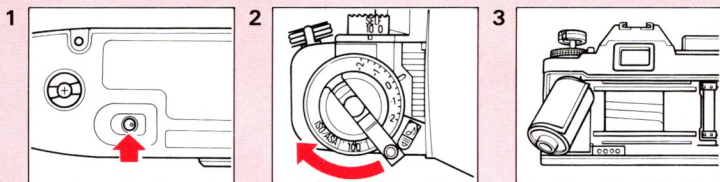

Fig. 30

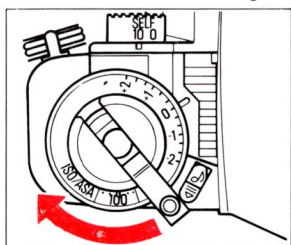

Fig. 31

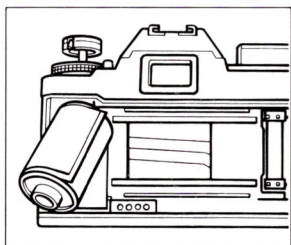

Fig. 32

REWIND THE FILM

(Do not expose the film to direct sunlight when unloading the film.)

1. Push the Film Rewind Release Button. The button stays locked in position (Fig. 30)
2. Unfold the Film Rewind Crank and turn it in the arrow direction. When the film has been completely rewound, the tension of the Film Rewind Crank is suddenly released and turns freely. (Fig. 31)
3. Open the Back Cover and unload the film. (Fig. 32)

- ★ Never open the Back Cover until film rewinding is completed. Immediately close the Back Cover to save some of your shots if the Back Cover is opened by mistake during or before rewinding.
- ★ If you wind the film beyond the set number of frames, the Film Advance Lever may get stuck mid-strokes. The Film Rewind Release Button will not stay depressed in. If this occurs, rewind the film while holding the Film Rewind Release Button pressed down.

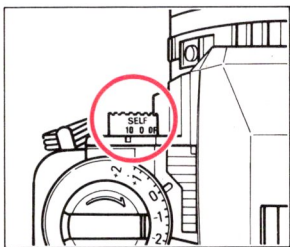
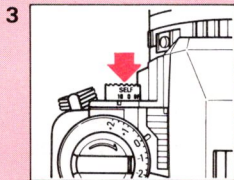
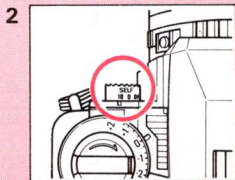
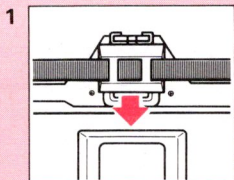

Fig. 33

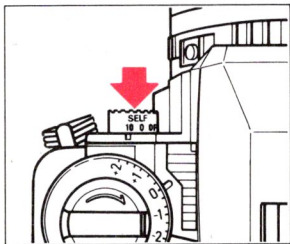

Fig. 34

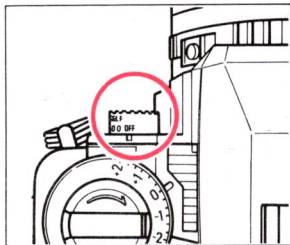

Fig. 35

SELF-TIMER PHOTOGRAPHY

The self-timer is used to include yourself in party pictures or commemorative shots.

1. Advance the film.
 2. Set "10" in the Self position on the Self/Interval Timer to the index line. (Fig. 33)
 3. Press the Self/Interval Timer Button. The Self-Timer Indicator Lamp blinks and the self-timer audible beep is heard. In 10 seconds, the shutter is automatically released. (Fig. 34)
 4. After shooting is completed, turn the Self/Interval Timer OFF. (Fig. 35)
- ★ To cancel the self-timer after it is set, press the Self/Interval Timer Button again or turn the Self/Interval Timer OFF.

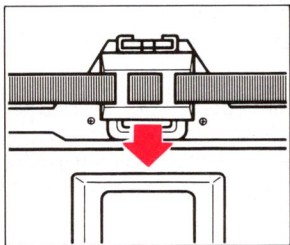

Fig. 36

- ★ Use the Viewfinder Cap attached to the strap to cover the Viewfinder Eyepiece when using the self-timer in modes other than "Manual" to avoid incorrect exposure due to incident-light from the Viewfinder Eyepiece. (Fig. 36)

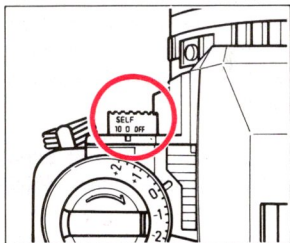

Fig. 37

- ★ Set "0" in the Self position to the index line to release the shutter instantly when the Self/Interval Timer Button is pressed. This serves as a handy "Left-Hand" shutter release. (Fig. 37)

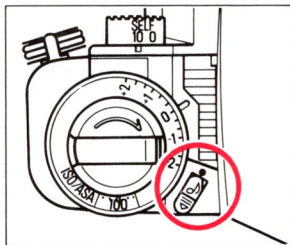

Fig. 38

- ★ B (Bulb) setting is not available when the Self-Timer is used.
- ★ The Self-Timer sound can be eliminated with the Beep Switch. (Fig. 38)

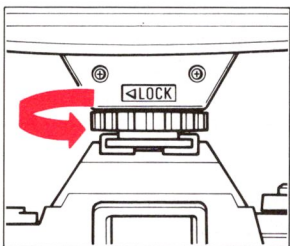
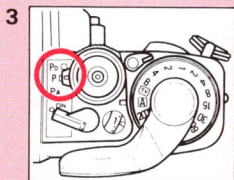
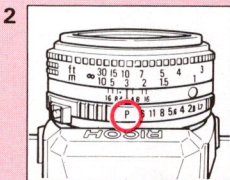
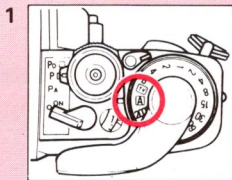

Fig. 39

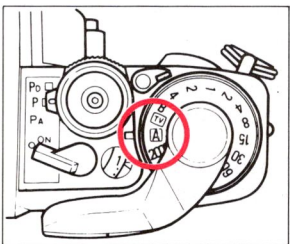

Fig. 40

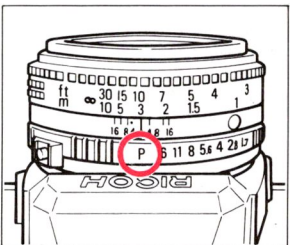

Fig. 41

FLASH PHOTOGRAPHY (PROGRAMMED FLASH PHOTOGRAPHY)

If the RICOH SPEEDLITE 300P is used on the RICOH XR-P camera, the shutter speed and the f-stop number are automatically set with the camera is set to program AE photography.

Flash photography is direct metering system and light is measured off the film plane to control the flash duration. This make possible a world of special applications as well as the ultimate in "Point and Shoot" simplicity.

1. Slide the flash unit into the Hot Shoe and tighten it with the lock screw. (Fig. 39)
2. Set the Shutter Speed Dial to "A". (Fig. 40)
3. Set the F-Stop Ring to "P". (Fig. 41)

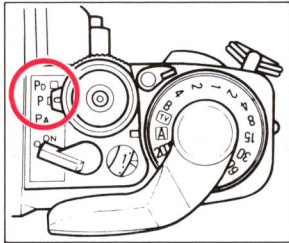
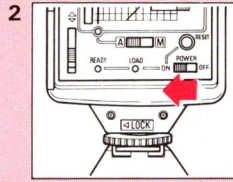
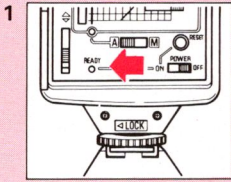

Fig. 42

4. Set the Program Selector to "P". (Fig. 42)

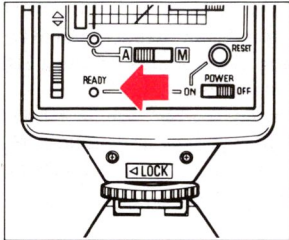

Fig. 43

5. Set the flash A/M selector to "A". (Fig. 43)

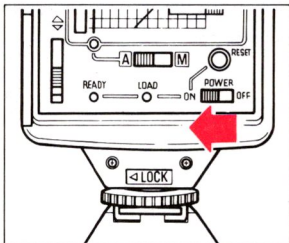

Fig. 44

6. Turn the flash power on-off switch ON. (Fig. 44)

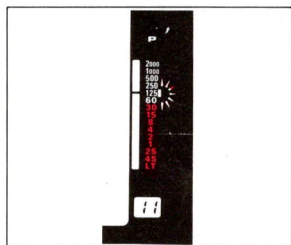

Fig. 45

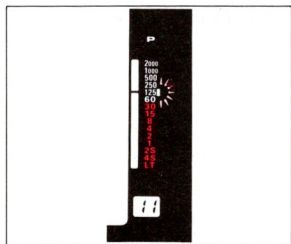

Fig. 46

7. When fully charged, the Flash Ready Indicator (red LED) lights in the finder. (Fig. 45)

Focus the subject and press the Shutter Release Button for shooting.

8. When flash shot is made with correct exposure, the Flash Ready Indicator/Correct Auto Flash Indicator (red LED) blinks for one second.

Exposure is not correct when it does not blink. Change taking conditions (F-Stop, Distance etc.) and try shooting again. (Fig. 46)

- ★ Refer to Operating Instructions for the flash unit for more creative techniques and technical details.

Pd



P

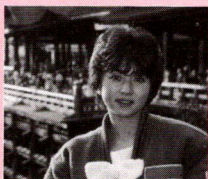

PA

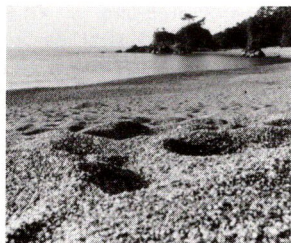
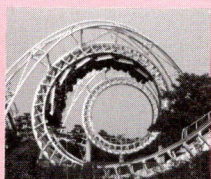

Fig. 47



Fig. 48

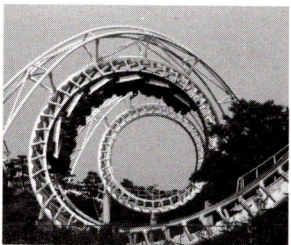

Fig. 49

APPLICATIONS

HOW TO USE MULTI-PROGRAM

The RICOH XR-P camera is designed with a Multi-Program system. 3-"customized" programs can be chosen by the Program Selector according to taking conditions and subject.

1. Pd program:

This is used for shooting with a deeper focus (an increased depth-of-field) as in scenery or close-up shots. (Fig. 47)

2. P program:

An "average" shutter speed and f-stop number are combined. This program is used for general shooting. (Fig. 48)

3. PA program:

This program is used for fast moving subjects as in sports, car races etc. This program bias wider apertures with decreased depth-of-field. This results in a less sharp background. This is ideally suited for portrait taking. (Fig. 49)

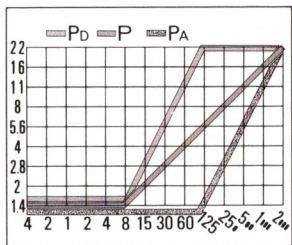
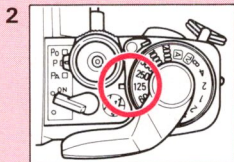
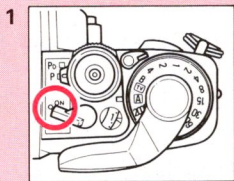

Fig. 50

- ★ Fig. 50 shows 3 programs of XR-P which will give you a general idea of the combination of shutter speed and aperture in 3 different programs (PD, P, PA).



MANUAL

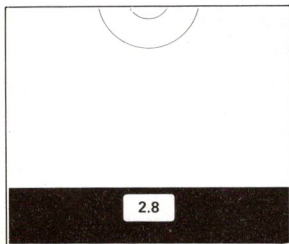

Fig. 51

APERTURE-PRIORITY AE PHOTOGRAPHY

In aperture-priority AE photography, the camera automatically sets correct shutter speeds according to a pre-selected f-stop number and brightness of subjects. This is suitable for photography taking advantage of specific depth-of-field results as in portraits or scenery pictures.

1. Set the Shutter Speed Dial to "A".
2. Turn the F-Stop Ring to set the desired f-stop number. The f-stop number can be seen in the bottom area of the viewfinder through the Aperture Relay Port. (Fig. 51)

When the Shutter Speed Indicator is in the orange range, the shutter speed is too slow. Select a new f-stop number or mount the camera on a tripod or other suitable platform.

- ★ When overexposure mark (▲) or underexposure mark (▼) appears in the viewfinder, exposure is not correct. Turn the F-Stop Ring to change the f-stop number.

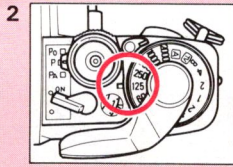
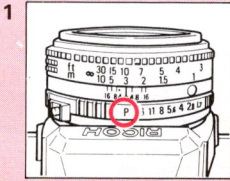

MANUAL

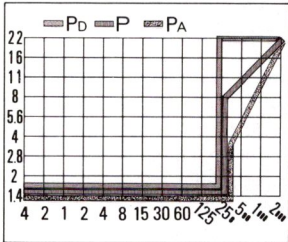

Fig. 52

SHUTTER BIAS PROGRAM AE PHOTOGRAPHY

The shutter bias program AE photography is a combination of the program AE photography and shutter speed priority AE photography. Use this mode to avoid shutter speeds lower than the pre-selected shutter speed as in sports photography.

For example, set the Shutter Speed Dial at 250 to avoid any shutter speed slower than 1/250 second.

When the subject is bright enough, any shutter speed between 1/250 and 1/2000 sec. will be selected according to the brightness of the subject, and you can see the selected shutter speed as well as f-stop number in the viewfinder. If the brightness of the subject is not enough even at full-open aperture, a slower shutter speed is automatically selected to obtain correct exposure. In this case, the Shutter Speed Indicator blinks to warn that a slower shutter speed than 1/250 is selected. (Fig. 52)

1. Turn the F-Stop Ring to set to "P".
2. Turn the Shutter Speed Dial to set the desired shutter speed.

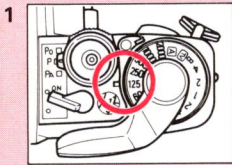

MANUAL

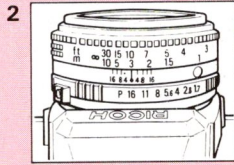

MANUAL

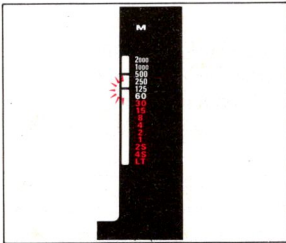

Fig. 53

MANUAL PHOTOGRAPHY

Select manual mode to manually set the shutter and the f-stop number in unusual or creative picture taking situations.

1. Set the Shutter Speed Dial to the desired speed.
2. The pre-set shutter speed is shown by the Indicator on the LCD meter display. A second Indicator blinks to indicate a "suggested" speed at a given f-stop. (Fig. 53)
3. When the F-Stop Ring is turned and the Shutter Speed Indicator and the blinking Indicator showing correct exposure overlap each other. This indicates that correct exposure is set. The f-stop number can also be checked without taking your eye away from the viewfinder.

Shutter Speed Dial	Program Selector	System of TV
TV	Pd	PAL or SECAM
	P	NTSC
	PA	Still TV Images

TV MODE

Use this mode to take TV images.

1. Set the program Selector according to the system of the television.
2. Set the Shutter Speed Dial to "TV" (Fig. 54).
3. Turn the F-Stop Ring to the "P" setting.
4. TV indicating TV mode, shutter speed and f-stop number are shown on the LCD meter display.

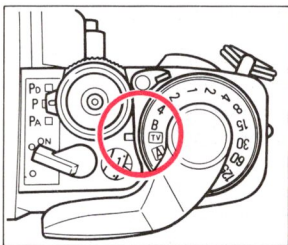

Fig. 54

Shutter Speed Dial	Program Selector	System of TV	Country	Shutter Speed
TV	Pd	PAL or SECAM	In Europe	1/25 sec.
	P	NTSC	In U.S. & Japan	1/30 sec.
	PA	Still TV images (Used for computers, etc.)		1/4 sec.

- ★ Use a tripod in TV mode, to avoid camera shake, because slow shutter speed are used.
- ★ The f-stop number is automatically selected according to brightness of TV images. It is not necessary to adjust f-stop.

-
- ★ In order to achieve correct exposure, compose TV images to fill the frame completely.
 - ★ Use of a tripod is absolutely necessary for PA, because the shutter speed is very slow. Be careful about unintentional movement of the camera in taking pictures.
 - ★ Compensation filters are available on the market to remove strong blue cast in TV images.
 - ★ TV images cannot be taken if the flash unit is used.

When the Speedlite 300P is used, it does not fire even when the switch is "ON" in TV mode.

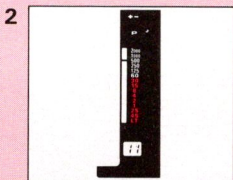
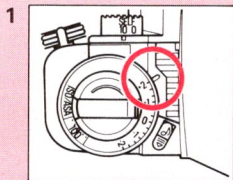

Fig. 55

Fig. 56

EXPOSURE COMPENSATION

The XR-P center-weighted meter can be "fooled" under very extreme lighting conditions.

When back light or spot light is given to the subject in AE photography and contrast is excessive between the background and the subject, under (dark) or over (too bright) exposed pictures result. Exposure compensation is used in such cases. It is also used to intentionally take over or underexposed pictures for creative effects etc.

1. Turn the Exposure Compensation Dial to set it to the required number. (Fig. 55)

- ★ Be sure to set it back to "0" position after use.
- ★ When the Exposure Compensation Dial is set at positions other than 0, + and - is displayed on the viewfinder LCD. (Fig. 56)

Exposure adjustment examples:

SUBJECT	EXPOSURE ADJUSTMENT
Figures in back light Scenery with much sky	+2 to +1
Figures with snow mountains or sea on the background	+1
Figures in spot light (on stage etc.)	-2 to -1

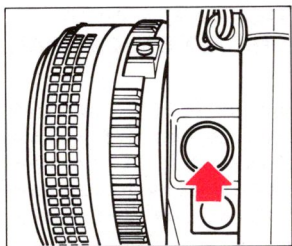

Fig. 57

AE LOCK

When back light or spot light is given to the subject in AE photography and contrast is excessive between the background and the subject, under (too dark) or over (too bright) exposed pictures result. Use AE Lock to "remember" or lock into the camera's electronic brain a close-up reading of the subject. This reading is used usually taken of a flesh-tone (face).

1. Bring the camera close to the subject to the point that exposure is not affected by the background.
 2. Press the AE Lock Button once to memorize the exposure. A flickering AEL is displayed in the viewfinder. (Fig. 57)
 3. AE Lock is automatically released when the Shutter Release Button is pressed for the shot.
- ★ Press AE Lock Button a second time to cancel without taking a picture.
 - ★ AE Lock can be used continuously if the AE Lock Button is kept pressed in.

FLASH PHOTOGRAPHY WITH RICOH FLASH UNIT OTHER THAN 300P

Ricoh flash units (SPEEDLITE 400, 240 and 180) can be used with XR-P with the Shutter Speed Dial set to "A", however, auto flash control is done by the sensor on flash unit and direct off the film metering is not available.

- ★ When the flash is fully charged, the Flash Ready Indicator in the viewfinder will light up.
- ★ Shutter speed is automatically set to 1/125 sec.

Setting F-Stop Ring of the lens

With SPEEDLITE 240:

Set the F-Stop Ring to "P". The camera selects proper f-stop number automatically.

With SPEEDLITE 180 & 400:

Set the F-Stop Ring to the designated number.

- ★ You may set shutter speed and f-stop number manually but shutter speed must be slower than 1/125 sec., however, when you select shutter speed faster than 1/125 sec., the shutter speed is automatically set to 1/125 sec.
- ★ Refer to Operating Instructions for flash units for further details.

FLASH PHOTOGRAPHY WITH "NON-DEDICATED" FLASH UNITS (General use of flash)

1. Set the Shutter Speed Dial to 1/125 sec. when a generic flash unit is used.
Note: Such units cannot be used in A (Auto) mode.
2. Connect the synchro cord to the synchro socket if the flash is not equipped with a hot shoe connection.
 - ★ Avoid use of flash units other than RICOH with special contact pins, incorrect exposure or other problems may result.
 - ★ The Flash Ready lamp does not light in the viewfinder if such a "non-dedicated" flash is used.
 - ★ Refer to operating instructions for these flash units for further details.

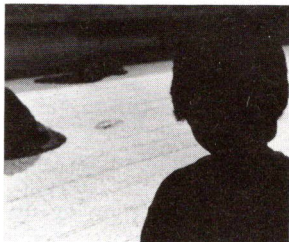
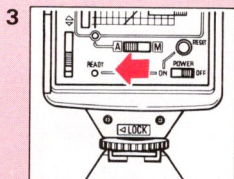
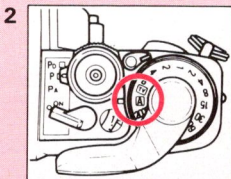
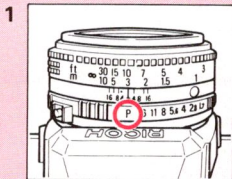

Fig. 58A



Fig. 58B

FLASH IN DAYLIGHT

The subject is affected by strong background light when taking pictures in back light. Dark pictures (faces, etc.) may be produced. Well lit pictures can be obtained by using flash even in daylight. This is known as "fill-flash".

When the SPEEDLITE 300P is used on XR-P, pro daylight flash can be easily accomplished even by novice photographers. (Fig. 58)

1. Set the flash unit on the camera, set the flash A/M (Auto/Manual) selector to "A" and turn the power ON-OFF switch ON.
 2. Set the camera in the program AE photography mode.
 3. When fully charged, the Flash Ready Indicator (red LED) lights in the viewfinder and the shutter speed is set automatically to 1/125 sec. Then, the f-stop number is displayed in the viewfinder. Now you can shoot (if you don't see an overexposure (▲) mark).
- ★ The Shutter Speed Dial set to "A" can be changed to manual shutter speeds (1/125 sec. or lower). Use longer manual speeds to give correct exposure to the background in a room or other dark place.

MORE EXCITING XR-P/300P APPLICATIONS

(Aperture-priority flash photography)

When the SPEEDLITE 300P for RICOH XR-P is used, direct film metering is available with all f-stop numbers for total creative depth of field control. Use F2 or F2.8 to take a distant subject or to reduce flash charge time. Use F11 or F16 to increase depth of field.

- ★ Check the Correct Auto Flash Indicator to verify that the flash worked properly after shooting.

DEPTH OF FIELD (GENERAL GUIDE LINES)

When you focus on a specific subject, often subjects in the near foreground and in the distance are also in focus. The region of good focus has some measurable depth, or "depth of field" as shown here.

1. Focus depth in the near foreground is narrow and deeper with distance.
2. Greater depth of field is obtained with smaller lens opening and a wider range of good focus is provided.
3. A lens of shorter focal length (wider angle) produces a greater depth of field. A greater depth is obtained with a wide angle lens (E.G. 28 mm) and a smaller depth is obtained with a telephoto lens (E.G. 135 mm).

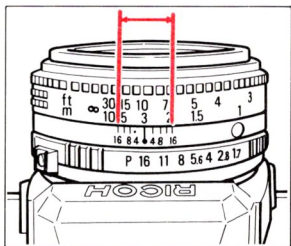

Fig. 59

The depth of field can be checked in the following way.

1. A depth of field indicator is engraved on every lens. When a 50 mm standard lens is set to f-16 and focused at a distance of 3 meters, the depth of field indicator is the scale of numbers on each side of ↓ mark, ranging from 16 to 16 (about 2m to 8m). Subjects in this distance range will be in good focus. (Fig. 59)

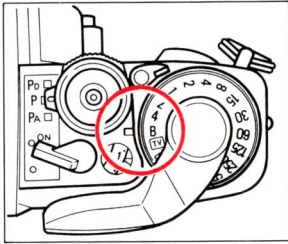

Fig. 60

B (BULB) SETTING

The B (Bulb) setting is used for shooting night scenes or long time exposures.

1. Set the Shutter Speed Dial to "B". (Fig. 60)
 2. When the Shutter Release Button is pressed, the shutter is kept open as long as the Button is pressed.
- ★ Use a tripod and cable release for Bulb photography to prevent unintentional movement of the camera.

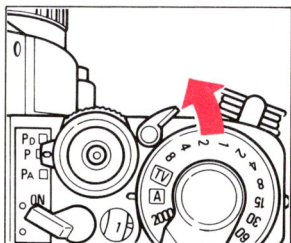
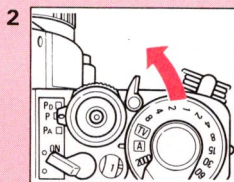
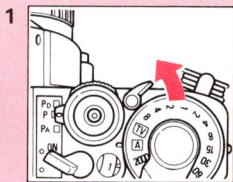

Fig. 61

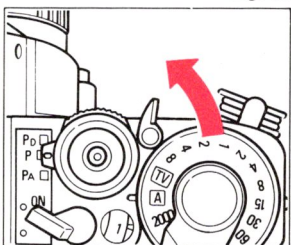

Fig. 62

MULTIPLE EXPOSURE PHOTOGRAPHY

The multiple exposure capability is used to take several different images on the same film frame.

1. Press the Shutter Release Button to make the first shot.
 2. Turn the ME Lever to the first click position. (About 30°) (Fig. 61)
 3. Turn the Film Advance Lever. Then the ME Lever is automatically set back to the original position. ME setting is now released and the film is normally advanced for the next exposure.
 4. Press the Shutter Release Button to make the second shot.
- ★ Turn the ME Lever to the second click position (About 60°) to make multiple exposures. Then the ME Lever will not return to the original position even if the Film Advance Lever is operated. (Fig. 62)
 - ★ The Exposure Counter will not advance during multiple exposure photography.
 - ★ When you ask camera shops to print your pictures, you had better tell them that multiple exposures were taken. If not, they may take them for "accidental" double exposures and not print your shots.

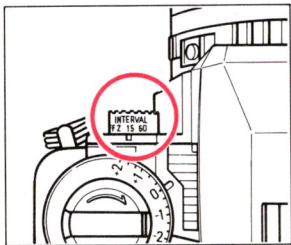

Fig. 63

INTERVAL TIMER PHOTOGRAPHY

The XR-P camera is equipped with a handy, built-in Interval Timer.

The Interval Timer is used to automatically take pictures at regular intervals as in observation or recording of wild animals or plants.

1. Mount the XR winder 2 or motor drive on the camera and turn the power switch ON.
 2. Turn the Self/Interval Timer to 2 sec., 15 sec. or 60 sec. as desired. (Fig. 63)
 3. Press the Self/Interval Timer Button to start shooting. An exposure will be taken at the preset interval until films end or until you set the Self/Interval Timer in OFF position.
- ★ To eliminate electronic sound during interval photography, turn the Beep Switch OFF.

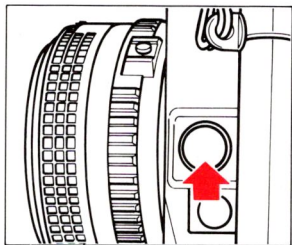

Fig. 64

VIEWFINDER LIGHTING

Auxiliary lighting can be used when the finder area is dark and difficult to see. Press the AE Lock Button to activate the LCD Illuminator. This also "memorize" the exposure data.

Press AE Lock Button once again to unlock AE, and to return to normal operation. (Fig. 64)

POWER ON-OFF SWITCH

XR-P is designed to shut off the power supply automatically to save the battery energy, i.e. the electric supply will be shut off automatically when the camera is not in use for 1 minute even the Power ON-OFF Switch is ON. Press the Shutter Release button lightly to turn ON the power. However, we suggest you should turn the power ON-OFF Switch to the OFF position when the camera is not used.

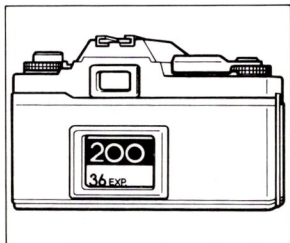

Fig. 65

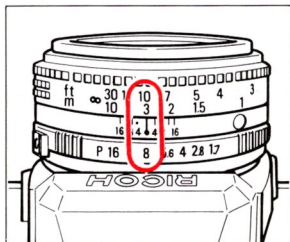

Fig. 66

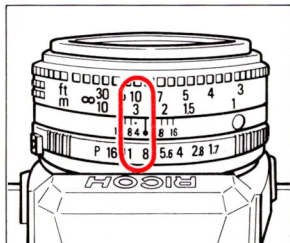

Fig. 67

MEMO HOLDER

Cut off the flap of the film package to be loaded and slide it into the Memo Holder on the Back Cover to remind you what type of film is loaded in the camera. (Fig. 65)

INFRARED MARK

Use the Infrared Focusing mark when using infrared film and R60 filter.

This is necessary because infrared light rays have a longer wave length than visible light rays, visual focusing will not accurate without some compensation.

1. Attach the R60 filter and focus on the subject. Read the distance from the lens barrel. (Fig. 66)
2. Shift the distance setting to the infrared index mark. (Fig. 67)

Set the exposure and release the shutter in accordance with operating instructions for the film.

- ★ Always refer to infrared film operating instructions when the infrared film is used.



Fig. 68

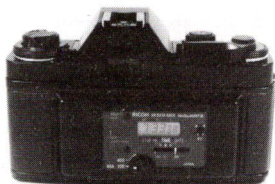

Fig. 69

XR WINDER 2

XR winder 2 is the automatic film winding device for XR-P.

When this is used on XR-P, you need not avert your eyes from the viewfinder to advance the film during fast action photography. This means fewer missed photo opportunities and better compositions.

This is very convenient in taking sports pictures. 2 frames per second can be taken if the Shutter Release Button is kept pressed. One frame shooting is possible when the Shutter Release Button is released quickly. 4 AA 1.5V batteries (manganese, alkaline, or nickel cadmium) are used for its power source. (Fig. 68)

XR DATA BACK

When the Back Cover of XR-P camera is replaced by the XR Data Back, "Year, month and date" "Hour, minute, second" and "Stop watch" can be printed on your film.

The automatic dating mechanism is incorporated into the XR Data Back. Once the date is set, no adjustment is necessary until 1999, because leap years and months with 31 or less days are automatically adjusted. When the switch is turned OFF, it can be used as digital watch. (Fig. 69)

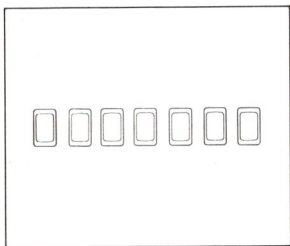

Fig. 70

DIOPTRIC LENSES

If a dioptic lens is fitted, you do not have to wear eye-glasses when taking pictures. Slip the lens in the groove in the finder eyepiece.

Dioptic lenses are available in 7 types:

-4, -3, -2, -1, +1, +2 and +3 (Diopters)
(Fig. 70)

Note: Some forms of astigmatism etc. may make dioptic eyepiece correction impossible. Please check with your vision specialist for a recommendation based on your prescription.

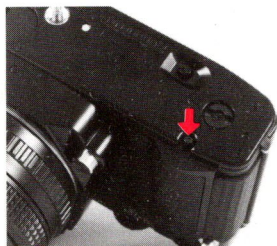

Fig. 71

RELEASE GRIP

The release grip is available for the XR-P as an optional accessory.

1. Push the hand grip release button on the bottom of your camera to remove the standard grip. (Fig. 71)



Fig. 72

2. Press two release grip pegs into camera body holes to snap the release grip into place. (Fig. 72)

P MOUNT ADAPTOR

Conventional P mount lens (screw mount lens) can be used on XR-P by using the optional P mount adaptor. Normal photography is available but operating conditions are slightly changed.

- A. Program exposure does not work (due to a different lens coupling system).
- B. Auto (Full Aperture) diaphragm is not functional.
- C. Automatic f-stop number setting with the special flash unit is not functional.

1. Align with the red dot and attach it into the body mount. (Fig. 73)



Fig. 73

2. Use a ball-point pen, etc. to turn it clockwise to the limit (65°). It is then locked and ready for use.
 3. Use a ball-point pen, etc. to press the spring inwards and turn the P mount adaptor counterclockwise to the limit. Now it can be removed.
- ★ Some screw mount lenses cannot be mounted on the XR-P camera. Purchase of lenses for XR-P is recommended for optimum results.

CARE OF BATTERIES

1. After handling, do not leave sweat or grease on battery surface. This could result in poor contact. Wipe both ends of the battery with a clean cloth.
2. Do not attempt to disassemble the batteries and do not throw them into fire or expose to high temperatures.
3. When batteries are unloaded from the camera, keep them away from children. If a child should swallow a battery, immediately consult with a doctor. Battery chemicals are highly poisonous.
4. Unload batteries when the camera is not used for a long period of time.

CARE AND STORAGE OF YOUR CAMERA

- Do not touch the lens or mirror with your fingers to clean them. Blow dust away with a blower or wipe them gently with soft cloth.
- Shock, humidity or salt may make the camera malfunction. When you use your camera at the beach or in a place where chemicals are used, wipe it clean carefully.
Do not use chemically-treated dusters to clean the camera.
- Do not expose your camera to temperature extremes.
- Do not leave your camera in a car or at the beach or in high temperature conditions to prevent possible trouble.
- When using a tripod, do not try to force a long screw into the socket. (The screw length should be less than 5.7 mm.)
- Do not store your camera near a television, radio or other magnetic substance.
- Remove batteries from your camera before storing it. Store it in a humidity and dust free place.

SPECIFICATIONS

Type:

35 mm SLR with focal plane shutter and automatic electronic exposure control.

Photographic Modes:

Multi-program automatic exposure mode, aperture-priority automatic exposure mode, shutter bias automatic exposure mode, TV mode, TTL auto flash mode, and manual exposure mode.

Film Format and Frame Size:

35 mm film, J135, 24 × 36 mm

Lens Mount:

RICOH system RK mount

Shutter:

Electronically controlled, vertically moving metal focal plane shutter.

Automatic: 16 sec. to 1/2000 sec.

Manual: 4 sec. to 1/2000 sec.

B and TV

Self-Timer:

Operating time: 10 seconds

During operation, red lamp blinks and electronic sound is given.

Operating time: 0 second

Shutter release with your left hand

Interval Timer:

Operation time: 2 sec., 15 sec. or 60 sec.

Photography at regular intervals is possible with the winder 2 or motor drive.

Viewfinder:

Field of view covers 93% horizontally and vertically.

Magnification: 0.88X (with 50 mm F1.4 standard lens)

Displays in the viewfinder:

Exposure adjustment, AE lock, manual, program mode, TV mode, overexposure mark, shutter speed indicator, long time exposure, underexposure mark, bulb, battery low warning signal, and programmed f-stop number.

LED indicator: Flash ready indicator, correct auto flash indicator.

Optical readout type: F-stop number

Focusing:

Diagonal split-image spot in microprism band

Exposure Meter:

TTL full open metering for center-weighted average light reading (Direct film metering when SPEEDLITE 300P is used.)

Exposure Coupling Range:

EV0 to EV18 (with ASA 100 film, 50 mm F1.4 standard lens)

Film Speed Range:

ISO/ASA12 to 3200

Flash Terminal:

X synchro contact, sychro socket provided.

Exposure Adjustment:

Exposure adjustment system
(+2 to -2, in 1/3 steps), AE lock system

Film Advance:

Single stroke film advance lever, 135° winding angle and 35° stand-off.

Automatic Film Advance:

Possible with XR winder 2 or motor drive.

Exposure Counter:

Additive, automatic resetting.

Film Rewind:

Film rewind crank system.

Mirror:

Swing back type quick return mirror.

Back Cover

Hinged type, opened by pulling up
Film rewind knob.

Other Functions:

2 position multiple exposure device, interchangeable grip and direct contact for data back.

Power Source:

Four LR44 1.5V alkaline batteries, four SR44 1.55V silver oxide batteries or two CR-1/3N 3V lithium batteries.

Dimensions:

136 (W) × 88 (H) × 51 (D) mm (Body only)

Weight:

505g (Body only)

MEMO

MEMO

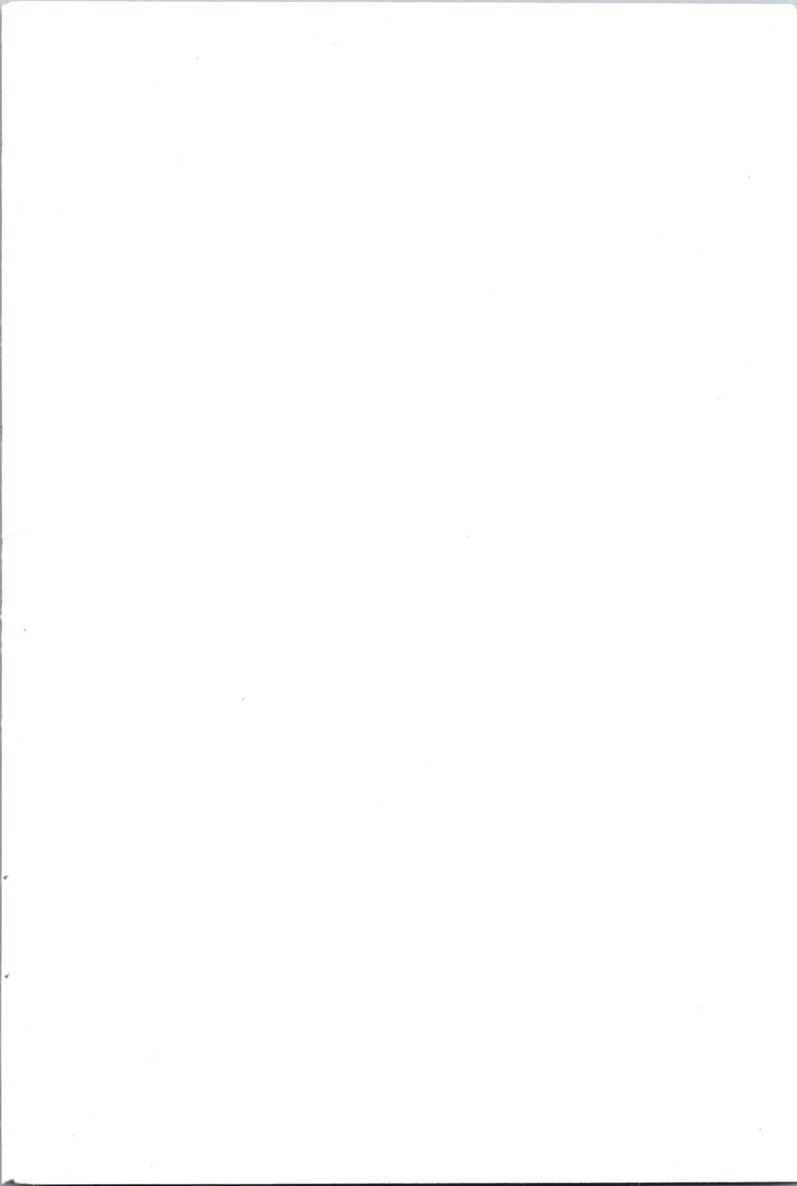

RICOH COMPANY, LTD.

14-6, 6-chome, Ginza, Chuo-ku, Tokyo, 104, Japan

RICOH CORPORATION

5 Dedrick Place West Caldwell, New Jersey 07006, U.S.A.

RICOH NEDERLAND B.V.

Alpen Rondweg 102, P.O. Box 114
Amstelveen – Holland

RICOH DEUTSCHLAND GmbH

Frankfurter Allee 45-47
6236 Eschborn 1
West Germany

RICOH BUSINESS MACHINES LTD.

2901, Wing on Centre, 111 Connaught Road
Central, Hong Kong